

16-bit Proprietary Microcontroller

CMOS

F²MC-16L MB90650A Series

MB90652A/653A/P653A

■ DESCRIPTION

The MB90650A series are 16-bit microcontrollers designed for high speed real-time processing in consumer product applications such as controlling cellular phones, CD-ROMs, or VTRs. Based on the F²MC¹-16 CPU core, an F²MC-16L is used as the CPU. This CPU includes high-level language-support instructions and robust task switching instructions, and additional addressing modes. In order to reduce the consumption current, dual-clock (main/sub) is used. Furthermore, low consumption power supply is achieved by using stop mode, sleep mode, watch mode, pseudo-watch mode, CPU intermittent operation mode.

Microcontrollers in this series have built-in peripheral resources including 10-bit A/D converter, 8-bit D/A converter, UART, 8/16-bit PPG, 8/16-bit up/down counter/timer, I²C interface^{*2}, 8/16-bit I/O timer (input capture, output compare, and 16-bit free-run timer).

*1:F²MC stands for FUJITSU Flexible Microcontroller.

*2:Purchase of Fujitsu I²C components conveys a license under the Philips I²C Patent Rights to use these components in an I²C system, provided that the system conforms to the I²C Standard Specification as defined by Philips.

■ FEATURES

F²MC-16L CPU

- Minimum execution time: 62.5 ns/4 MHz oscillation (Uses PLL clock multiplication) maximum multiplier = 4
- Instruction set optimized for controller applications
Object code compatibility with F²MC-16(H)

(Continued)

■ PACKAGE

100-pin Plastic LQFP

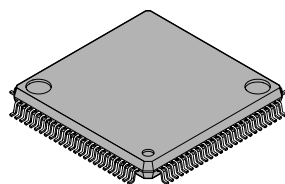

(FPT-100P-M05)

100-pin Plastic QFP

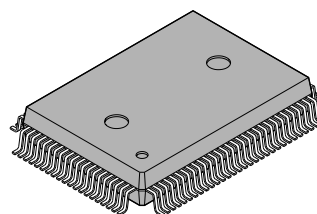

(FPT-100P-M06)

MB90650A Series

(Continued)

Wide range of data types (bit, byte, word, and long word)

Improved instruction cycles provide increased speed

Additional addressing modes: 23 modes

High code efficiency

Access methods (bank access, linear pointer)

High precision operations are enhanced by use of a 32-bit accumulator

Extended intelligent I/O service (access area extended to 64 Kbytes)

Maximum memory space: 16 Mbytes

- Enhanced high level language (C) and multitasking support instructions
 - Use of a system stack pointer
 - Enhanced pointer indirect instructions
 - Barrel shift instructions
- Improved execution speed: Four byte instruction queue
- Powerful interrupt function
- Automatic data transfer function that does not use instruction (extended I²OS)

MB90650A Series

■ PRODUCT LINEUP

Part number	MB90652A	MB90653A	MB90P653A	MB90V650A
Item				
Classification	Mask ROM product		OTPROM product	For evaluation
ROM size	64 Kbytes	128 Kbytes		—
RAM size	3 Kbytes	5 Kbytes		
Power supply voltage	2.2 V to 3.6 V		2.7 V to 5.5 V	
CPU functions	The number of instructions: Instruction bit length: Instruction length: Data bit length: Minimum execution time: Interrupt processing time:		340 8/16 bits 1 to 7 bytes 1/4/8/16/32 bits 62.5 ns/4 MHz (PLL multiplier = 4) 1.0 μ s/16 MHz (minimum)	
Ports	I/O ports (N-channel open-drain): I/O ports (CMOS): Total:		4 75 (Input pull-up resistors available: 24/ Can be set as N-channel open-drain: 8) 79	
A/D converter	Analog inputs : 8 channels 10-bit resolution Conversion time : minimum 6.13 μ s/16 MHz		Analog inputs: 8 channels 10-bit resolution Conversion time : minimum 12.25 μ s/8 MHz	
D/A converter	2 channels (independent), 8-bit resolution, R-2R type			
8/16-bit up/down counter/timer	16 bits \times 1 channel/8 bits \times 2 channels selectable Includes reload and compare functions.			
I ² C interface	1 channel Master mode/slave mode available			
UART	1 channel Clock synchronous communication Clock asynchronous communication			
I/O extended serial interface	8 bits \times 2 channels LSB-first or MSB-first operation selectable			
8/16-bit PPG	8 bits \times 2 channels/16 bits \times 1 channel selectable			
16-bit I/O timer	1 channel (Input capture \times 2 channels, output compare \times 4 channels, and free-run timer \times 1 channel)			
DTP/external interrupt	8 inputs			
Timer functions	Timebase timer (18-bit)/watchdog timer (18-bit)/watch timer (15-bit)			
Low-power consumption modes	CPU intermittent operation mode, sub clock mode, stop mode, sleep mode, watch mode, pseudo-watch mode			
PLL function	Selectable multiplier: 1/2/3/4 (Set a multiplier that does not exceed the assured operation frequency range.)			
Other	—		V _{PP} is shared with the MD2 pin (for EPROM programming)	—
Package	FPT-100P-M05, FPT-100P-M06			PGA-256C-A02

- Notes:
- MB90V650A device is assured only when operate with the tools, under the condition of power supply voltage: 2.7 V to 3.3 V, operating temperature: 0°C to 70°C and operating frequency: 1.5 MHz to 8MHz
 - For more information about each package, see seciton "■ Package Dimensions."

MB90650A Series

PIN ASSIGNMENT

(Top view)

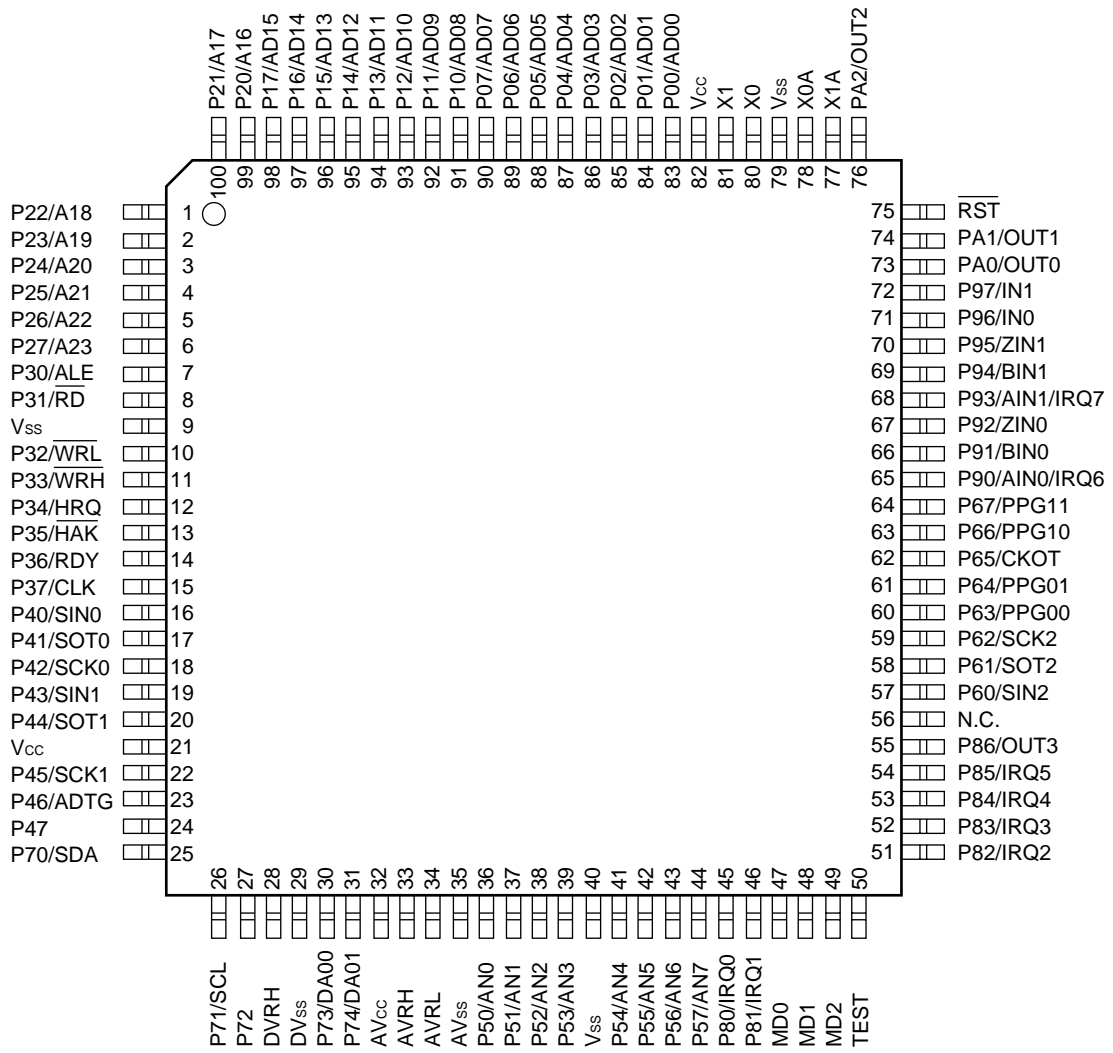

(FPT-100P-M05)

MB90650A Series

(Top view)

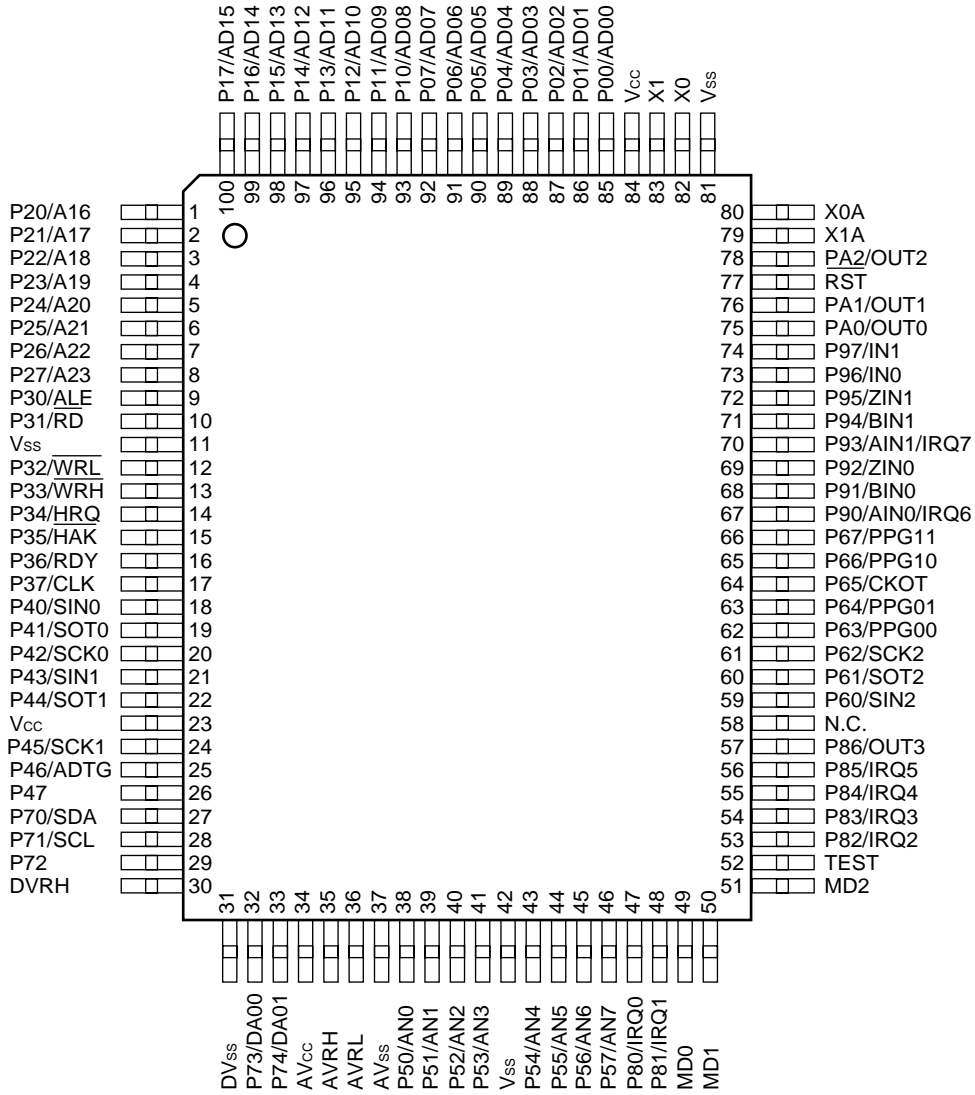

(FPT-100P-M06)

MB90650A Series

■ PIN DESCRIPTION

Pin no.		Pin name	Circuit type	Function
LQFP*1	QFP*2			
80	82	X0	A	Crystal oscillator pin
81	83	X1	A	Crystal oscillator pin
77	79	X1A	B	Crystal oscillatort pins (32 kHz)
78	80	X0A	B	Crystal oscillatort pins (32 kHz)
47 to 49	49 to 51	MD0 to MD2	D	Operating mode selection pins Connect directly to V _{CC} or V _{SS} .
50	52	TEST	D	Test input pin This pin must always be fixed to "H".
75	77	RST	C	Reset input pin
83 to 90	85 to 92	P00 to P07	E (STBC)	General-purpose I/O ports Pull-up resistors can be set (RD07 to RD00 = "1") using the pull-up resistor setting register (RDR0). The setting does not apply for ports set as outputs (D07 to D00 = "1": invalid at the output setting).
		AD00 to AD07		In external bus mode, the pins function as the lower data I/O or lower address outputs (AD00 to AD07).
91 to 98	93 to 100	P10 to P17	E (STBC)	General-purpose I/O ports Pull-up resistors can be set (RD17 to RD10 = "1") using the pull-up resistor setting register (RDR1). The setting does not apply for ports set as outputs (D17 to D10 = "1": invalid at the output setting).
		AD08 to AD15		In 16-bit external bus mode, the pins function as the upper data I/O or middle address outputs (AD08 to AD15).
99, 100, 1 to 6	1, 2, 3 to 8	P20, P21, P22 to P27	I (STBC)	General-purpose I/O ports In external bus mode, pins for which the corresponding bit in the HACR register is "0" function as the P20 to P27 pins.
		A16, A17, A18 to A23		In external bus mode, pins for which the corresponding bit in the HACR register is "1" function as the upper address output pins (A16 to A23).
7	9	P30	I (STBC)	General-purpose I/O port Functions as the ALE pin in external bus mode.
		ALE		Functions as the address latch enable signal.
8	10	P31	I (STBC)	General-purpose I/O port Functions as the \overline{RD} pin in external bus mode.
		\overline{RD}		Functions as the read strobe output (\overline{RD}).
10	12	P32	I (STBC)	General-purpose I/O port Functions as the \overline{WRL} pin in external bus mode if the WRE bit in the ECSR register is "1".
		\overline{WRL}		Functions as the lower data write strobe output (\overline{WRL}).

*1: FPT-100P-M05

*2: FPT-100P-M06

(Continued)

MB90650A Series

Pin no.		Pin name	Circuit type	Function
LQFP*1	QFP*2			
11	13	P33	I (STBC)	General-purpose I/O port Functions as the WRH pin in 16-bit external bus mode if the WRE bit in the ECSR register is "1".
		WRH		Functions as the upper data write strobe output (WRH).
12	14	P34	I (STBC)	General-purpose I/O port Functions as the HRQ pin in external bus mode if the HDE bit in the ECSR register is "1".
		HRQ		Functions as the hold request input pin (HRQ).
13	15	P35	I (STBC)	General-purpose I/O port Functions as the HAK pin in external bus mode if the HDE bit in the ECSR register is "1".
		HAK		Functions as the hold acknowledge output (HAK) pin.
14	16	P36	I (STBC)	General-purpose I/O port Functions as the RDY pin in external bus mode if the RYE bit in the ECSR register is "1".
		RDY		Functions as the external ready input (RDY) pin.
15	17	P37	I (STBC)	General-purpose I/O port Functions as the CLK pin in external bus mode if the CKE bit in the ECSR register is "1".
		CLK		Functions as the machine cycle clock output (CLK) pin.
16	18	P40	H (STBC)	General-purpose I/O port When UART0 is operating, the data at the pin is used as the serial input (SIN0). Can be set as an open-drain output port (OD40 = "1") by the open-drain control register (ODR4). The setting does not apply for ports set as inputs (D40 = "0": invalid at the input setting).
		SIN0		Functions as the UART0 serial input (SIN0).
17	19	P41	G (STBC)	General-purpose I/O port Functions as the SOT0 pin if the SOE bit in the UMC register is "1". Can be set as an open-drain output port (OD41 = "1") by the open-drain control register (ODR4). The setting does not apply for ports set as inputs (D41 = "0": invalid at the input setting).
		SOT0		Functions as the UART0 serial data output pin (SOT0).

*1: FPT-100P-M05

*2: FPT-100P-M06

(Continued)

MB90650A Series

Pin no.		Pin name	Circuit type	Function
LQFP*1	QFP*2			
18	20	P42	H (STBC)	General-purpose I/O port When UART0 is operating in external shift clock mode, the data at the pin is used as the clock input (SCK0). Also, functions as the SCK0 pin if the SOE bit in the UMC register is "1". Can be set as an open-drain output port (OD42 = "1") by the open-drain control register (ODR4). The setting does not apply for ports set as inputs (D42 = "0": invalid at the input setting).
		SCK0		Functions as the UART0 serial clock I/O pin (SCK0).
19	21	P43	H (STBC)	General-purpose I/O port When I/O extended serial is operating, the data at the pin is used as the serial input (SIN1). Can be set as an open-drain output port (OD43 = "1") by the open-drain control register (ODR4). The setting does not apply for ports set as inputs (D43 = "0": invalid at the input setting).
		SIN1		Functions as the serial input for I/O extended serial data.
20	22	P44	G (STBC)	General-purpose I/O port Functions as the SOT1 pin if the SOE bit in the UMC register is "1". Can be set as an open-drain output port (OD44 = "1") by the open-drain control register (ODR4). The setting does not apply for ports set as inputs (D44 = "0": invalid at the input setting).
		SOT1		Functions as the output pin (SOT1) for I/O extended serial data.
22	24	P45	H (STBC)	General-purpose I/O port When I/O extended serial is operating in external shift clock mode, the data at the pin is used as the clock input (SCK1). Also, functions as the SCK1 pin if the SOE bit in the UMC register is "1". Can be set as an open-drain output port (OD45 = "1") by the open-drain control register (ODR4). The setting does not apply for ports set as inputs (D45 = "0": invalid at the input setting).
		SCK1		Functions as the I/O extended serial clock I/O pin (SCK1).
23	25	P46	G (STBC)	General-purpose I/O port Can be set as an open-drain output port (OD46 = "1") by the open-drain control register (ODR4). The setting does not apply for ports set as inputs (D46 = "0": invalid at the input setting).
		ADTG		Functions as the external trigger input pin for the A/D converter.
24	26	P47	K (NMOS/H) (STBC)	Open-drain type general-purpose I/O port

*1: FPT-100P-M05

*2: FPT-100P-M06

(Continued)

MB90650A Series

Pin no.		Pin name	Circuit type	Function
LQFP*1	QFP*2			
36 to 39, 41 to 44	38 to 41, 43 to 46	P50 to P53, P54 to P57	L (STBC)	General-purpose I/O ports
		AN0 to AN3, AN4 to AN7		The pins are used as analog inputs (AN0 to AN7) when the A/D converter is operating.
57	59	P60	F (STBC)	General-purpose I/O port A pull-up resistor can be set (RD60 = "1") using the pull-up resistor setting register (RDR6). The setting does not apply for ports set as outputs (D60 = "1": invalid at the output setting).
		SIN2		Functions as a data input pin (SIN2) for I/O extended serial.
58	60	P61	E (STBC)	General-purpose I/O port Function as the SOT2 pin if the SOE bit in the UMC register is "1". A pull-up resistor can be set (RD61 = "1") using the pull-up resistor setting register (RDR6). The setting does not apply for ports set as outputs (D61 = "1": invalid at the output setting).
		SOT2		Functions as an output pin (SOT2) for I/O extended serial data.
59	61	P62	F (STBC)	General-purpose I/O port When I/O extended serial is operating in external shift clock mode, the data at the pin is used as the clock input (SCK2). Also, functions as the SCK2 pin if the SOE bit in the UMC register is "1". A pull-up resistor can be set (RD62 = "1") using the pull-up resistor setting register (RDR6). The setting does not apply for ports set as outputs (D62 = "1": invalid at the output setting).
		SCK2		Functions as the I/O extended serial clock I/O pin (SCK2).
60	62	P63	E (STBC)	General-purpose I/O port A pull-up resistor can be set (RD63 = "1") using the pull-up resistor setting register (RDR6). The setting does not apply for ports set as outputs (D63 = "1": invalid at the output setting).
		PPG00		Functions as the PPG00 output when PPG output is enabled.
61	63	P64	E (STBC)	General-purpose I/O port A pull-up resistor can be set (RD64 = "1") using the pull-up resistor setting register (RDR6). The setting does not apply for ports set as outputs (D64 = "1": invalid at the output setting).
		PPG01		Functions as the PPG01 output when PPG output is enabled.

*1: FPT-100P-M05

*2: FPT-100P-M06

(Continued)

MB90650A Series

Pin no.		Pin name	Circuit type	Function
LQFP*1	QFP*2			
62	64	P65	E (STBC)	General-purpose I/O port A pull-up resistor can be set (RD65 = "1") using the pull-up resistor setting register (RDR6). The setting does not apply for ports set as outputs (D65 = "1": invalid at the output setting).
		CKOT		Functions as the CKOT output when CKOT is operating.
63	65	P66	E (STBC)	General-purpose I/O port A pull-up resistor can be set (RD66 = "1") using the pull-up resistor setting register (RDR6). The setting does not apply for ports set as outputs (D66 = "1": invalid at the output setting).
		PPG10		Functions as the PPG10 output when PPG output is enabled.
64	66	P67	E (STBC)	General-purpose I/O port A pull-up resistor can be set (RD67 = "1") using the pull-up resistor setting register (RDR6). The setting does not apply for ports set as outputs (D67 = "1": invalid at the output setting).
		PPG11		Functions as the PPG11 output when PPG output is enabled.
25	27	P70	K (NMOS/H) (STBC)	Open-drain type I/O port
		SDA		I ² C interface data I/O pin This function is valid when I ² C interface operations are enabled. Set port output to Hi-Z (PDR = 1) during I ² C interface operations.
26	28	P71	K (NMOS/H) (STBC)	Open-drain type I/O port
		SCL		I ² C interface clock I/O pin This function is valid when I ² C interface operations are enabled. Set port output to Hi-Z (PDR = 1) during I ² C interface operations.
27	29	P72	K (STBC)	Open-drain type I/O port
30	32	P73	M (STBC)	Open-drain type I/O port Functions as a D/A output pin when DAE0 = "1" in the D/A control register (DACR).
		DA00		Functions as D/A output 0 when the D/A converter is operating.
31	33	P74	M (STBC)	General-purpose I/O port Functions as a D/A output pin when DAE1 = "1" in the D/A control register (DACR).
		DA01		Functions as D/A output 1 when the D/A converter is operating.
45	47	P80	J	General-purpose I/O port
		IRQ0		Functions as external interrupt request I/O 0.

*1: FPT-100P-M05

*2: FPT-100P-M06

(Continued)

MB90650A Series

Pin no.		Pin name	Circuit type	Function
LQFP*1	QFP*2			
46	48	P81	J	General-purpose I/O port
		IRQ1		Functions as external interrupt request I/O 1.
51	53	P82	J	General-purpose I/O port
		IRQ2		Functions as external interrupt request I/O 2.
52	54	P83	J	General-purpose I/O port
		IRQ3		Functions as external interrupt request I/O 3.
53	55	P84	J	General-purpose I/O port
		IRQ4		Functions as external interrupt request I/O 4.
54	56	P85	J	General-purpose I/O port
		IRQ5		Functions as external interrupt request I/O 5.
55	57	P86	I (STBC)	General-purpose I/O port This applies in all cases.
		OUT3		Event output for channel 3 of the output compare
65	67	P90	J	General-purpose I/O port
		AIN0		Input to channel 0 of the 8/16-bit up/down counter/timer
		IRQ6		Functions as an interrupt request input.
66	68	P91	J (STBC)	General-purpose I/O port
		BIN0		Input to channel 0 of the 8/16-bit up/down counter/timer
67	69	P92	J (STBC)	General-purpose I/O port
		ZIN0		Input to channel 0 of the 8/16-bit up/down counter/timer
68	70	P93	J	General-purpose I/O port
		AIN1		Input to channel 1 of the 8/16-bit up/down counter/timer
		IRQ7		Functions as an interrupt request input.
69	71	P94	J (STBC)	General-purpose I/O port
		BIN1		Input to channel 1 of the 8/16-bit up/down counter/timer
70	72	P95	J (STBC)	General-purpose I/O port
		ZIN1		Input to channel 1 of the 8/16-bit up/down counter/timer
71	73	P96	J (STBC)	General-purpose I/O port
		IN0		Trigger input for channel 0 of the input capture
72	74	P97	J (STBC)	General-purpose I/O port
		IN1		Trigger input for channel 1 of the input capture
73	75	PA0	I (STBC)	General-purpose I/O port
		OUT0		Event output for channel 0 of the output compare

*1: FPT-100P-M05

*2: FPT-100P-M06

(Continued)

MB90650A Series

(Continued)

Pin no.		Pin name	Circuit type	Function
LQFP*1	QFP*2			
74	76	PA1	I (STBC)	General-purpose I/O port
		OUT1		Event output for channel 1 of the output compare
76	78	PA2	I (STBC)	General-purpose I/O port
		OUT2		Event output for channel 2 of the output compare
82	84	V _{CC}	—	Power supply (3.0 V) input pin
21	23	V _{CC}	—	Power supply (3.0 V) input pin
9, 40, 79	11, 42, 81	V _{SS}	—	Power supply (0.0 V) input pin
32	34	AV _{CC}	—	A/D converter power supply pin
33	35	AVRH	—	A/D converter external reference power supply pin
34	36	AVRL	—	A/D converter external reference power supply pin
35	37	AV _{SS}	—	A/D converter power supply pin
28	30	DVRH	—	D/A converter external reference power supply pin
29	31	DV _{SS}	—	D/A converter power supply pin
56	58	N.C.	—	N.C. pin This pin must be open as an open pin.

*1: FPT-100P-M05

*2: FPT-100P-M06

Note: STBC = Incorporates standby control
NMOS = N-ch open-drain output

MB90650A Series

■ I/O CIRCUIT TYPE

Type	Circuit	Remarks
A		<ul style="list-style-type: none"> Oscillation feedback resistance : Approx. 1 MΩ
B		<ul style="list-style-type: none"> Oscillation feedback resistance : Approx. 10 MΩ
C		<ul style="list-style-type: none"> Hysteresis input with pull-up Resistance approx. 50 kΩ
D		<ul style="list-style-type: none"> Hysteresis input port
E		<ul style="list-style-type: none"> Incorporates pull-up resistor control (for input) CMOS level I/O Resistance approx. 50 kΩ
F		<ul style="list-style-type: none"> Incorporates pull-up resistor control (for input) CMOS level output Hysteresis input Resistance approx. 50 kΩ

(Continued)

MB90650A Series

Type	Circuit	Remarks
G	<p>Open-drain control signal</p> <p>CMOS</p> <p>R</p>	<ul style="list-style-type: none"> • CMOS level I/O • Incorporates open-drain control
H	<p>Open-drain control signal</p> <p>Hysteresis input</p> <p>R</p>	<ul style="list-style-type: none"> • CMOS level output • Hysteresis input • Incorporates open-drain control
I	<p>CMOS</p> <p>R</p>	<ul style="list-style-type: none"> • CMOS level I/O
J	<p>Hysteresis input</p> <p>R</p>	<ul style="list-style-type: none"> • CMOS level output • Hysteresis input
K	<p>Digital output</p> <p>Hysteresis input</p> <p>R</p>	<ul style="list-style-type: none"> • Hysteresis input • N-ch open-drain output
L	<p>CMOS</p> <p>Analog input</p> <p>R</p>	<ul style="list-style-type: none"> • CMOS level I/O • Analog input

(Continued)

MB90650A Series

(Continued)

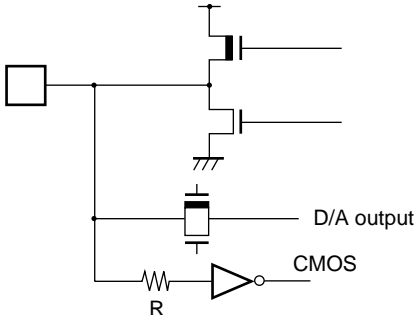
Type	Circuit	Remarks
M		<ul style="list-style-type: none"> • CMOS level I/O • Analog output • Shared with D/A outputs

MB90650A Series

■ HANDLING DEVICES

1. Preventing Latch-up

Latch-up occurs in a CMOS IC if a voltage greater than V_{CC} or less than V_{SS} is applied to an input or output pin or if the voltage applied between V_{CC} and V_{SS} exceeds the rating.

If latch-up occurs, the power supply current increases rapidly resulting in thermal damage to circuit elements. Therefore, ensure that maximum ratings are not exceeded in circuit operation.

For the same reason, also ensure that the analog supply voltage does not exceed the digital supply voltage.

2. Treatment of Unused Pins

Leaving unused input pins unconnected can cause misoperation. Always pull-up or pull-down unused pins.

3. External Reset Input

To reliably reset the controller by inputting an “L” level to the \overline{RST} pin, ensure that the “L” level is applied for at least five machine cycles. Take particular note when using an external clock input.

4. V_{CC} and V_{SS} Pins

Ensure that all V_{CC} pins are at the same voltage. The same applies for the V_{SS} pins.

5. Precautions when Using an External Clock

Drive the X0 pin only when using an external clock.

• Using an external clock

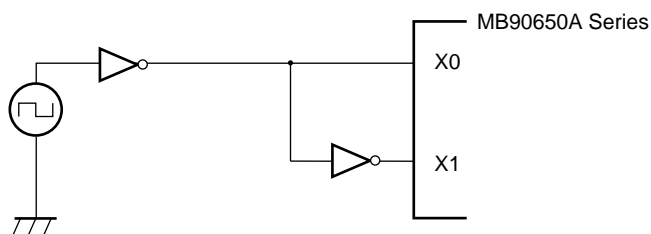

6. A/D Converter Power Supply and the Turn-on Sequence for Analog Inputs

Always turn off the A/D converter power supply (AV_{CC} , $AVRH$, $AVRL$) and analog inputs (AN0 to AN7) before turning off the digital power supply (V_{CC}).

When turning the power on or off, ensure that $AVRH$ does not exceed AV_{CC} .

Also, when using the analog input pins as input ports, ensure that the input voltage does not exceed AV_{CC} .

7. Turn-on Sequence for D/A Converter Power Supply

Always turn on the D/A converter power supply (DVR), after turning off the digital power supply (V_{CC}).

And in the turning off the power supply sequence always turn off the digital power supply (V_{CC}) after turning off the D/A converter power supply (DVR).

8. Initializing

In this device there are some kinds of inner registers which are initialized only by power on reset. It is possible to initialize these registers by turning on the power supply again.

9. Power Supply Pins

When there are several V_{CC} and V_{SS} pins, those pins that should have the same electric potential are connected within the device when the device is designed in order to prevent misoperation, such as latchup. However, all of those pins must be connected to the power supply and ground externally in order to reduce unnecessary emissions, prevent misoperation of strobe signals due to an increase in the ground level, and to observe the total output current standards.

In addition, give a due consideration to the connection in that current supply be connected to V_{CC} and V_{SS} with the lowest possible impedance.

Finally, it is recommended to connect a capacitor of about 0.1 μF between V_{CC} and V_{SS} near this device as a bypass capacitor.

10. Crystal Oscillation Circuit

Noise in the vicinity of the X0 and X1 pins will cause this device to operate incorrectly. Design the printed circuit board so that the bypass capacitor connecting X0, X1 and the crystal oscillator (or ceramic oscillator) to ground is located as close to the device as possible, and that the wiring does not cross the other wirings.

In addition, because printed circuit board artwork in which the area around the X0 and X1 pins is surrounded by ground provides stable operation, such an arrangement is strongly recommended.

MB90650A Series

■ PROGRAMMING FOR MB90P653A

In EPROM mode, the MB90P653A functions equivalent to the MBM27C1000/1000A. This allows the EPROM to be programmed with a general-purpose EPROM programmer by using the dedicated socket adapter (do not use the electronic signature mode).

1. Program Mode

When shipped from Fujitsu, and after each erasure, all bits (128 K × 8 bits) in the MB90P653A are in the “1” state. Data is written to the ROM by selectively programming “0” into the desired bit locations. Bits cannot be set to “1” electrically.

2. Programming Procedure

- (1) Set the EPROM programmer to MBM27C1000/1000A.
- (2) Load program data into the EPROM programmer at 00000_H to 1FFFF_H.

Note that ROM addresses FE0000_H to FFFFFFF_H in the operation mode in the MB90P653A series assign to 00000_H to 1FFFF_H in the EPROM mode (on the EPROM programmer).

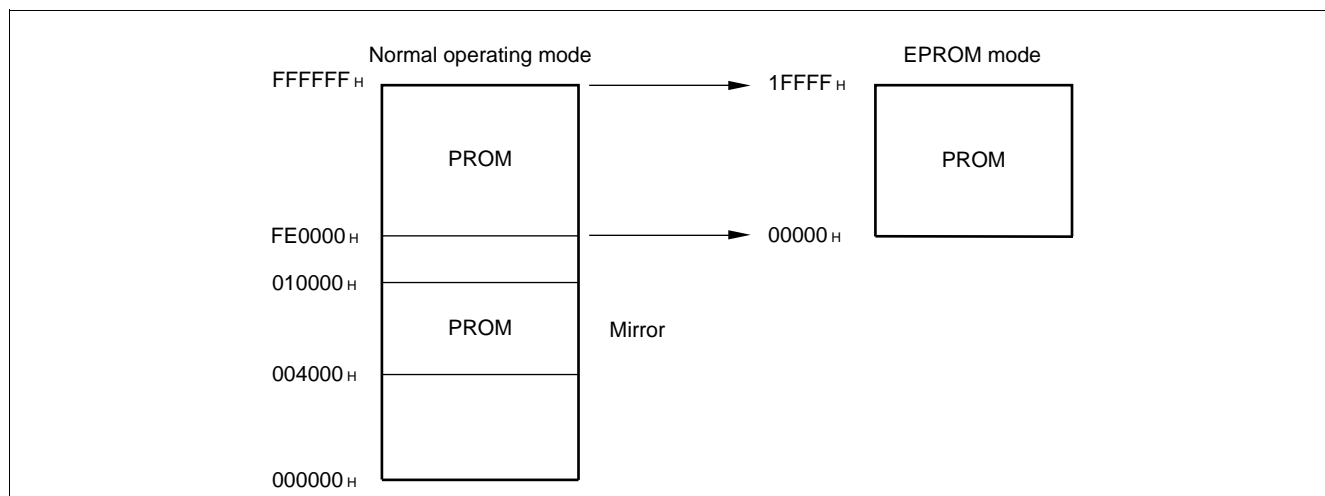

The 00 bank PROM mirror is 48 Kbytes. (This is a mirror for FF4000_H to FFFFFFF_H.)

- (3) Mount the MB90P653A on the adapter socket, then fit the adapter socket onto the EPROM programmer. When mounting the device and the adapter socket, pay attention to their mounting orientations.
- (4) Start programming the program data to the device.
- (5) If programming has not successfully resulted, connect a capacitor of approx. 0.1 μF between V_{CC} and GND, between V_{PP} and GND.

Note: The mask ROM products (MB90653A, MB90652A) does not support EPROM mode. Data cannot, therefore, be read by the EPROM programmer.

MB90650A Series

3. EPROM Programmer Socket Adapter

Part no.	MB90652APFV	MB90653APFV	MB90P653APFV	MB90652APF	MB90653APF	MB90P653APF
Package	LQFP-100			QFP-100		
Compatible socket adapter Sun Hayato Co., Ltd.	ROM-100SQF-32DP-16L			ROM-100QF-32DP-16L		

Inquiry: Sun Hayato Co., Ltd.: TEL: (81)-3-3986-0403
FAX: (81)-3-5396-9106

4. Recommended Screening Conditions

High temperature aging is recommended as the pre-assembly screening procedure.

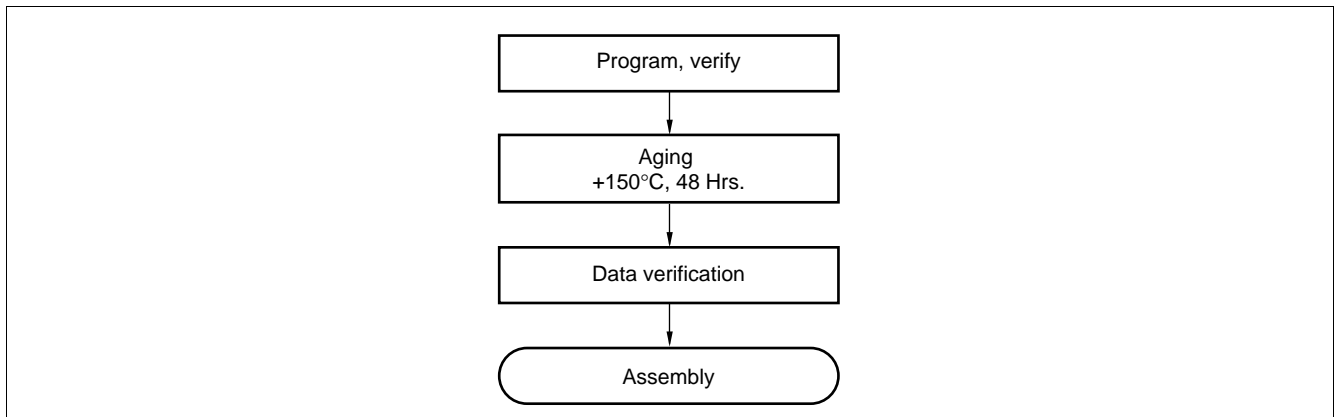

5. Programming Yield

MB90P653A cannot be write tested for all bits due to their nature. Therefore the write yield cannot always be guaranteed to be 100%.

MB90650A Series

6. EPROM Mode Pin Assignments

- MBM27C1000/1000A compatible pins

MBM27C1000/1000A		MB90P653A		MBM27C1000/1000A		MB90P653A	
Pin no.	Pin name	Pin no.	Pin name	Pin no.	Pin name	Pin no.	Pin name
1	V _{PP}	See "Pin Assignment."	MD2	32	V _{CC}	See "Pin Assignment."	V _{CC}
2	\overline{OE}		P32	31	PGM		P33
3	A15		P17	30	N.C.		—
4	A12		P14	29	A14		P16
5	A07		P27	28	A13		P15
6	A06		P26	27	A08		P10
7	A05		P25	26	A09		P11
8	A04		P24	25	A11		P13
9	A03		P23	24	A16		P30
10	A02		P22	23	A10		P12
11	A01		P21	22	\overline{CE}		P31
12	A00		P20	21	D07		P07
13	D00		P00	20	D06		P06
14	D01		P01	19	D05		P05
15	D02		P02	18	D04		P04
16	GND		V _{SS}	17	D03		P03

- Non-MBM27C1000/1000A compatible pins

Pin no.	Pin name	Treatment
	MD0 MD1 X0	Connect a pull-up resistor of 4.7 k Ω .
	X1 to X1A	OPEN
	AV _{CC} AVRH P37 P40 to P47 P50 to P57 P60 to P67 P70 to P74 P80 to P86 P90 to P97 PA0 to PA2 N.C. TEST	Connect a pull-up resistor of about 1 M Ω to each pin.

- Power supply, GND connection pins

Classification	Pin no.	Pin name
Power supply	See "Pin Assignment."	HST V _{CC} DVRH
GND	See "Pin Assignment."	P34 P35 P36 RST AVRL AV _{SS} DV _{SS} V _V

MB90650A Series

■ BLOCK DIAGRAM

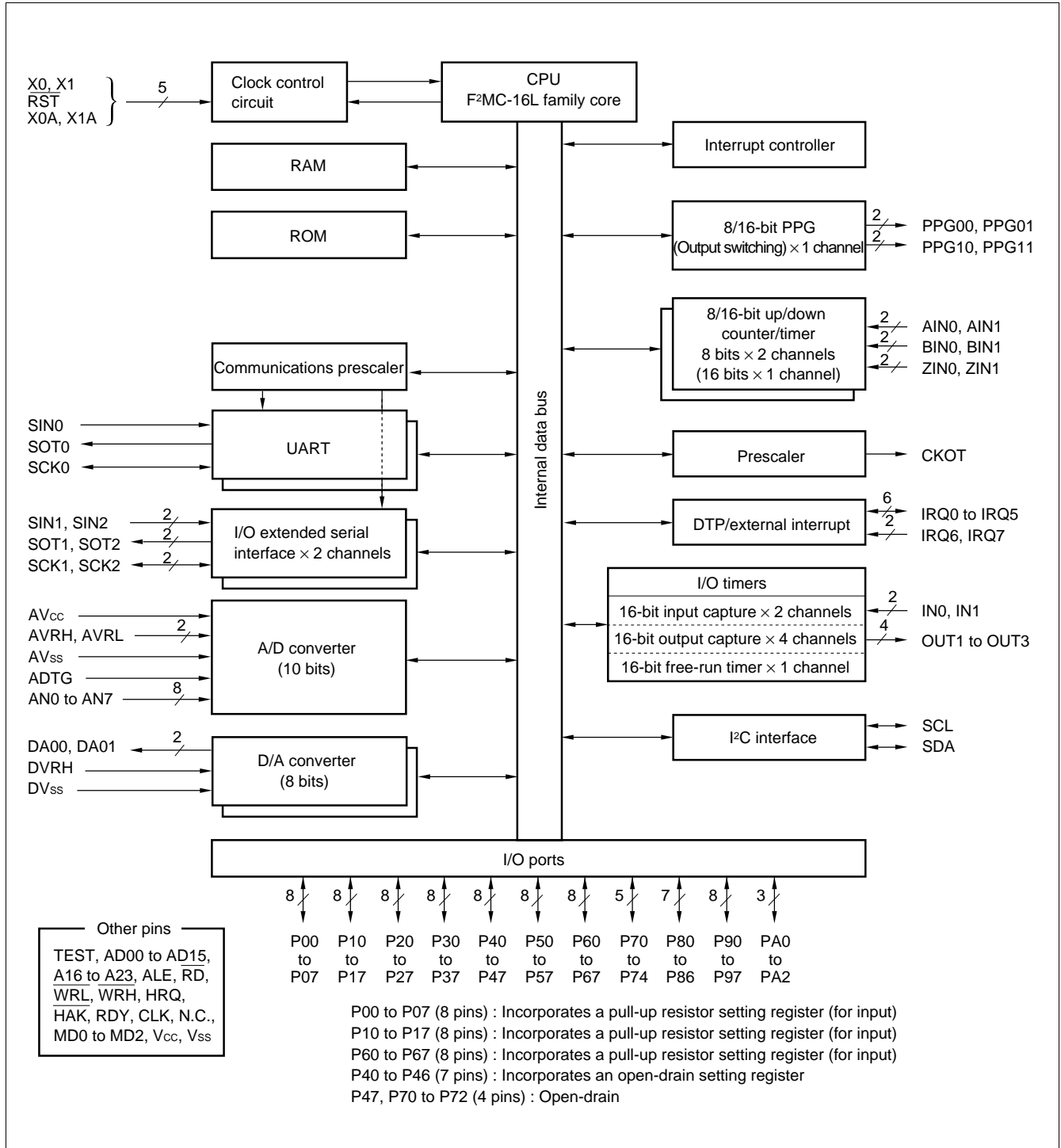

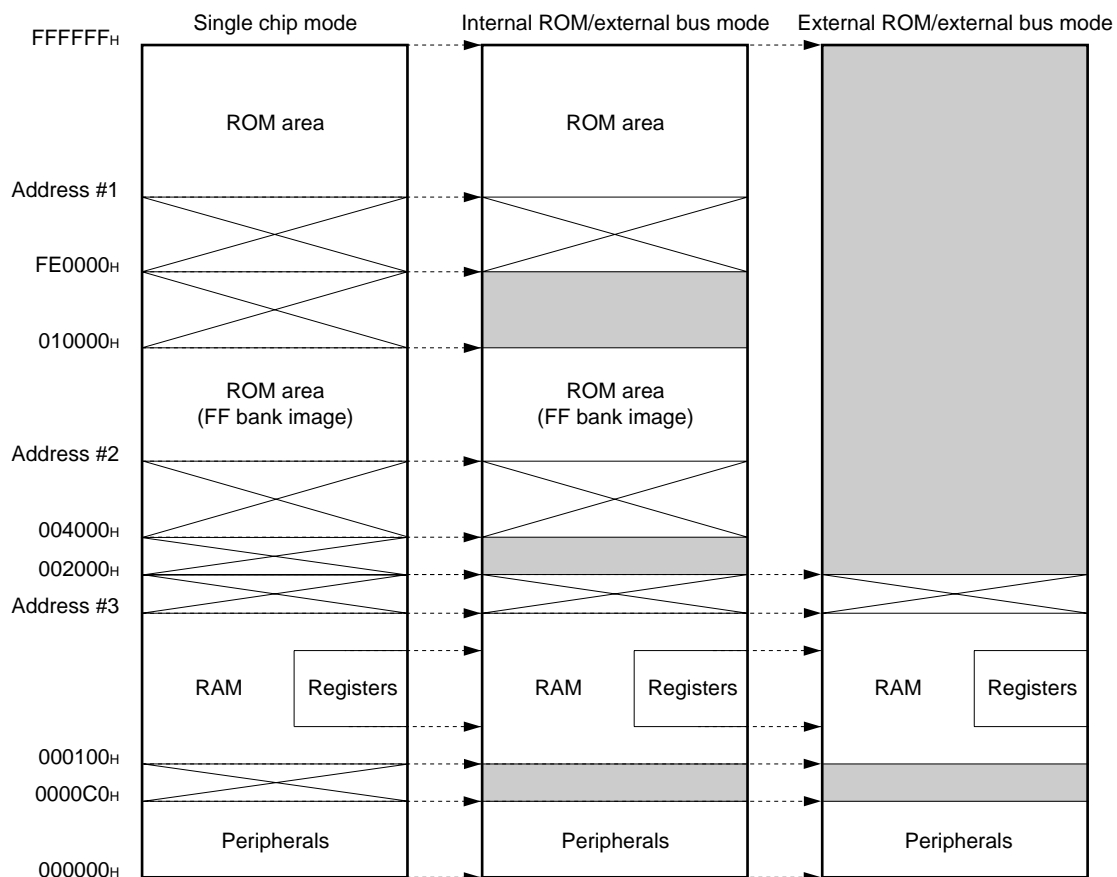

MB90650A Series

MEMORY MAP



Type	Address #1*	Address #2*	Address #3*
MB90652	FF0000H	004000H	000CFFH
MB90653	FE0000H	004000H	0014FFH
MB90P653	FE0000H	004000H	0014FFH

 : Internal access memory

 : External access memory

 : No access

*: Address #1, #2, and #3 are different owing to their devices respectively.

Notes: While the ROM data image of bank FF can be seen in the upper portion of bank 00, this is done only to permit effective use of the C compiler's small model. Because the lower 16 bits are the same, it is possible to reference tables in ROM without declaring the "far" specification in the pointer.

For example, to access to 00C000H is to access to the ROM content of FFC000H in practice.

Because the ROM area of FF bank exceeds 48 Kbytes, all the area can be seen in bank 00.

So, the image for FF4000H to FFFFFFFH can be seen in bank 00, while FE0000H to FF3FFFH can only be seen in bank FF and FE.

MB90650A Series

■ F²MC-16L CPU PROGRAMMING MODEL

• Dedicated registers

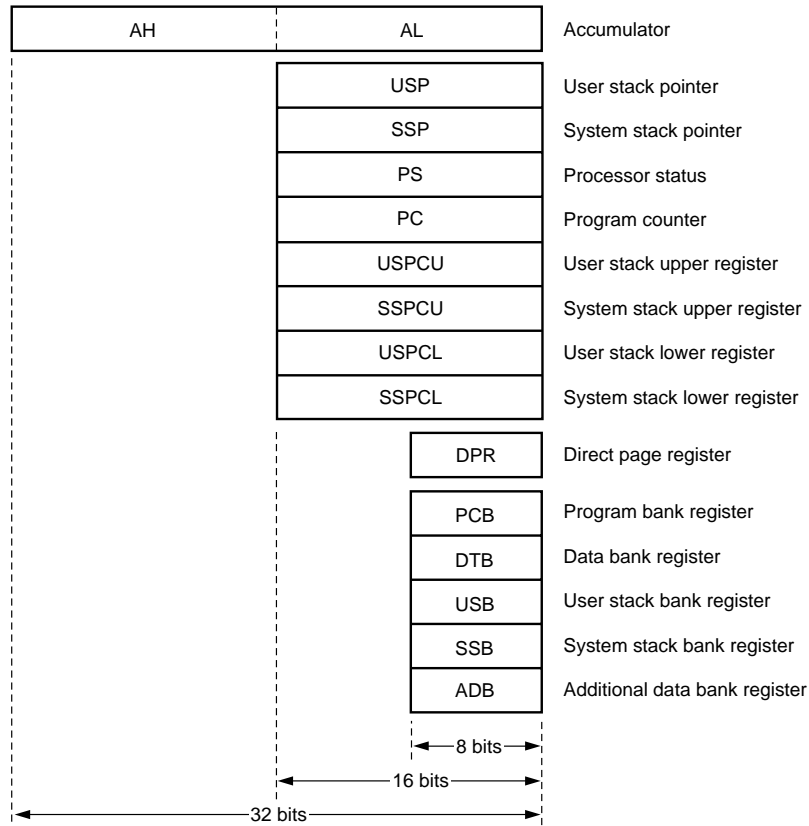

• General-purpose registers

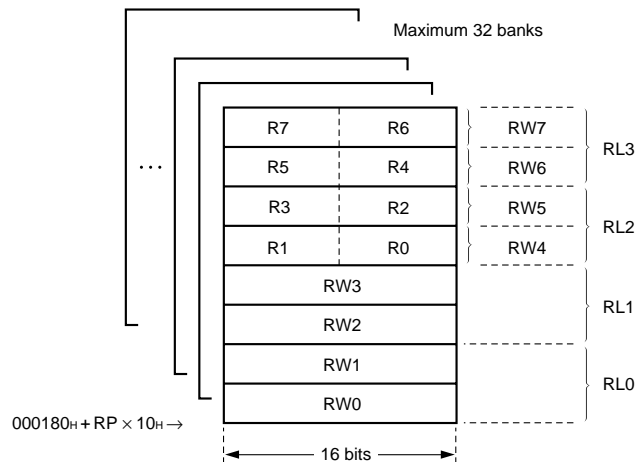

• Processor status (PS)

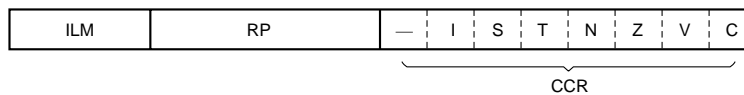

MB90650A Series

■ I/O MAP

Address	Register	Register name	Read/write	Resource name	Initial value
00 _H	Port 0 data register	PDR0	R/W	Port 0	XXXXXXXX _B
01 _H	Port 1 data register	PDR1	R/W	Port 1	XXXXXXXX _B
02 _H	Port 2 data register	PDR2	R/W	Port 2	XXXXXXXX _B
03 _H	Port 3 data register	PDR3	R/W	Port 3	XXXXXXXX _B
04 _H	Port 4 data register	PDR4	R/W	Port 4	1XXXXXXXX _B
05 _H	Port 5 data register	PDR5	R/W	Port 5	XXXXXXXX _B
06 _H	Port 6 data register	PDR6	R/W	Port 6	XXXXXXXX _B
07 _H	Port 7 data register	PDR7	R/W	Port 7	---XX111 _B
08 _H	Port 8 data register	PDR8	R/W	Port 8	-XXXXXXXX _B
09 _H	Port 9 data register	PDR9	R/W	Port 9	XXXXXXXX _B
0A _H	Port A data register	PDRA	R/W	Port A	-----XX _B
0B _H to 0F _H	(Reserved area)				
10 _H	Port 0 direction register	DDR0	R/W	Port 0	00000000 _B
11 _H	Port 1 direction register	DDR1	R/W	Port 1	00000000 _B
12 _H	Port 2 direction register	DDR2	R/W	Port 2	00000000 _B
13 _H	Port 3 direction register	DDR3	R/W	Port 3	00000000 _B
14 _H	Port 4 direction register	DDR4	R/W	Port 4	-0000000 _B
15 _H	Port 5 direction register	DDR5	R/W	Port 5	00000000 _B
16 _H	Port 6 direction register	DDR6	R/W	Port 6	00000000 _B
17 _H	Port 7 direction register	DDR7	R/W	Port 7	----00---- _B
18 _H	Port 8 direction register	DDR8	R/W	Port 8	-0000000 _B
19 _H	Port 9 direction register	DDR9	R/W	Port 9	00000000 _B
1A _H	Port A direction register	DDRA	R/W	Port A	-----000 _B
1B _H	Port 4 pin register	ODR4	R/W	Port 4	-0000000 _B
1C _H	Port 0 resistance register	RDR0	R/W	Port 0	00000000 _B
1D _H	Port 1 resistance register	RDR1	R/W	Port 1	00000000 _B
1E _H	Port 6 resistance register	RDR6	R/W	Port 6	00000000 _B
1F _H	Analog input enable register	ADER	R/W	Port 5, A/D	11111111 _B
20 _H	Serial mode register 0	SMR0	R/W	UART0	00000000 _B
21 _H	Serial control register 0	SCR0	R/W		00000100 _B
22 _H	Serial input register/ serial output register 0	SIDR/ SODR0	R/W		XXXXXXXX _B

(Continued)

MB90650A Series

Address	Register	Register name	Read/write	Resource name	Initial value
23 _H	Serial status register 0	SSR0	R/W	UART0	00001-00 _B
24 _H	Serial mode control status register 0	SMCS0	R/W	I/O extended serial interface 0	----0000 _B
25 _H	Serial mode control status register 0	SMCS0	R/W		00000010 _B
26 _H	Serial data register 0	SDR0	R/W		XXXXXXXX _B
27 _H	Clock division control register	CDCR	R/W	Communications prescaler	0---1111 _B
28 _H	Serial mode control status register 1	SMCS1	R/W	I/O extended serial interface 1	----0000 _B
29 _H	Serial mode control status register 1	SMCS1	R/W		00000010 _B
2A _H	Serial data register 1	SDR1	R/W		XXXXXXXX _B
2B _H to 2F _H	(Reserved area)				
30 _H	Interrupt/DTP enable register	ENIR	R/W	DTP/external interrupts	00000000 _B
31 _H	Interrupt/DTP source register	EIRR	R/W		00000000 _B
32 _H	Request level setting register	ELVR	R/W		00000000 _B
33 _H					00000000 _B
34 _H to 35 _H	(Reserved area)				
36 _H	Control status register 1	ADCS1	R/W	A/D converter	00000000 _B
37 _H	Control status register 2	ADCS2			00000000 _B
38 _H	Data register 1	ADCR1	R		XXXXXXXX _B
39 _H	Data register 2	ADCR2			XXXXXXXX _B
3A _H	D/A converter data register 0	DAT0	R/W	D/A converter	XXXXXXXX _B
3B _H	D/A converter data register 1	DAT1	R/W		XXXXXXXX _B
3C _H	D/A control register channel 0	DACR0	R/W		-----0 _B
3D _H	D/A control register channel 1	DACR1	R/W		-----0 _B
3E _H	Clock control register	CLKR	R/W	Clock output control register	----0000 _B
3F _H	(Reserved area)				
40 _H	Reload register lower channel 0	PRL0	R/W	8/16-bit PPG	XXXXXXXX _B
41 _H	Reload register upper channel 0	PRLH0	R/W		XXXXXXXX _B
42 _H	Reload register lower channel 1	PRL1	R/W		XXXXXXXX _B
43 _H	Reload register upper channel 1	PRLH1	R/W		XXXXXXXX _B
44 _H	PPG0 operation mode control register channel 0	PPGC0	R/W		0X000XX1 _B
45 _H	PPG1 operation mode control register channel 1	PPGC1	R/W		0X000001 _B
46 _H	PPG0, PPG1 output control register channel 0, channel 1	PPGOE	R/W		00000000 _B
47 _H to 4F _H	(Reserved area)				
50 _H	Lower compare register channel 0	OCCP0	R/W	16-bit I/O timer output compare (channel 0 to channel 3)	XXXXXXXX _B

(Continued)

MB90650A Series

Address	Register	Register name	Read/write	Resource name	Initial value
51 _H	Upper compare register channel 0	OCCP0	R/W	16-bit I/O timer Output compare (channel 0 to channel 3)	XXXXXXXX _B
52 _H	Lower compare register channel 1	OCCP1	R/W		XXXXXXXX _B
53 _H	Upper compare register channel 1				XXXXXXXX _B
54 _H	Lower compare register channel 2	OCCP2	R/W		XXXXXXXX _B
55 _H	Upper compare register channel 2				XXXXXXXX _B
56 _H	Lower compare register channel 3	OCCP3	R/W		XXXXXXXX _B
57 _H	Upper compare register channel 3				XXXXXXXX _B
58 _H	Compare control status register channel 0	OCS0	R/W		0000--00 _B
59 _H	Compare control status register channel 1	OCS1	R/W		---00000 _B
5A _H	Compare control status register channel 2	OCS2	R/W		0000--00 _B
5B _H	Compare control status register channel 3	OCS3	R/W		---00000 _B
5C _H to 5F _H	(Reserved area)				
60 _H	Lower input capture register channel 0	IPCP0	R	16-bit I/O timer Input capture (channel 0, channel 1)	XXXXXXXX _B
61 _H	Upper input capture register channel 0		R		XXXXXXXX _B
62 _H	Lower input capture register channel 1	IPCP1	R		XXXXXXXX _B
63 _H	Upper input capture register channel 1		R		XXXXXXXX _B
64 _H	Input capture control status register	ICS0, 1	R/W		00000000 _B
65 _H	(Reserved area)				
66 _H	Lower timer data register	TCDTL	R/W	16-bit I/O timer Free-run timer (channel 0, channel 1)	00000000 _B
67 _H	Upper timer data register	TCDTH	R/W		00000000 _B
68 _H	Timer control status register	TCCS	R/W		00000000 _B
69 _H to 6F _H	(Reserved area)				
70 _H	Up/down count register channel 0	UDCR0	R	8/16-bit up/down counter/timer	00000000 _B
71 _H	Up/down count register channel 1	UDCR1			00000000 _B
72 _H	Reload compare register channel 0	RCR0	W		00000000 _B
73 _H	Reload compare register channel 1	RCR1			00000000 _B
74 _H	Counter status register channel 0	CSR0	R/W		00000000 _B
75 _H	(Reserved area)				
76 _H	Counter control register channel 0	CCRL0	R/W	8/16-bit up/down counter/timer	00001000 _B
77 _H		CCRH0			00000000 _B
78 _H	Counter status register channel 1	CSR1	R/W		00000000 _B
79 _H	(Reserved area)				
7A _H	Counter control register channel 1	CCRL1	R/W	8/16-bit up/down counter/timer	00000000 _B

(Continued)

MB90650A Series

Address	Register	Register name	Read/write	Resource name	Initial value
7B _H	Counter control register channel 1	CCR _H 1	R/W	8/16-bit up/down counter/timer	X0001000 _B
7C _H to 7F _H	(Reserved area)				
80 _H	I ² C bus status register	IBSR	R	I ² C interface	00000000 _B
81 _H	I ² C bus control register	IBCR	R/W		00000000 _B
82 _H	I ² C bus clock control register	ICCR	R/W		--0XXXXX _B
83 _H	I ² C bus address register	IADR	R/W		-XXXXXXXX _B
84 _H	I ² C bus data register	IDAR	R/W		XXXXXXXX _B
85 _H to 9E _H	(Reserved area) (Accessing 90 _H to 9E _H is prohibited.)				
9F _H	Delayed interrupt generation/release register	DIRR	R/W	Delayed interrupt generation module	-----0 _B
A0 _H	Low-power consumption mode control register	LPMCR	R/W	Low-power consumption mode	00011000 _B
A1 _H	Clock selection register	CKSCR	R/W	Low-power consumption mode	11111100 _B
A2 _H to A4 _H	(Reserved area)				
A5 _H	Auto-ready function selection register	ARSR	W	External bus pin control circuit	0011--00 _B
A6 _H	External address output control register	HACR	W	External bus pin control circuit	00000000 _B
A7 _H	Bus control signal selection register	ECSR	W	External bus pin control circuit	0000*00- _B
A8 _H	Watchdog timer control register	WDTC	R/W	Watchdog timer	XXXXX111 _B
A9 _H	Timebase timer control register	TBTC	R/W	Timebase timer	1--00000 _B
AA _H	Watch timer control register	WTC	R/W	Watch timer	1X-00000 _B
AB _H to AF _H	(Reserved area)				
B0 _H	Interrupt control register 00	ICR00	R/W	Interrupt controller	00000111 _B
B1 _H	Interrupt control register 01	ICR01	R/W		00000111 _B
B2 _H	Interrupt control register 02	ICR02	R/W		00000111 _B
B3 _H	Interrupt control register 03	ICR03	R/W		00000111 _B
B4 _H	Interrupt control register 04	ICR04	R/W		00000111 _B
B5 _H	Interrupt control register 05	ICR05	R/W		00000111 _B
B6 _H	Interrupt control register 06	ICR06	R/W		00000111 _B
B7 _H	Interrupt control register 07	ICR07	R/W		00000111 _B
B8 _H	Interrupt control register 08	ICR08	R/W		00000111 _B
B9 _H	Interrupt control register 09	ICR09	R/W		00000111 _B
BA _H	Interrupt control register 10	ICR10	R/W		00000111 _B
BB _H	Interrupt control register 11	ICR11	R/W		00000111 _B
BC _H	Interrupt control register 12	ICR12	R/W		00000111 _B
BD _H	Interrupt control register 13	ICR13	R/W	00000111 _B	

(Continued)

MB90650A Series

(Continued)

Address	Register	Register name	Read/write	Resource name	Initial value
BE _H	Interrupt control register 14	ICR14	R/W	Interrupt controller	00000111 _B
BF _H	Interrupt control register 15	ICR15	R/W		00000111 _B
C0 _H to FF _H	(External area)				

About Programming

R/W : Readable and writable

R : Read only

W : Write only

Explanation of initial values

0: The initial value of this bit is "0".

1: The initial value of this bit is "1".

* : The initial value of this bit is "0" or "1".

X: The initial value of this bit is undefined.

–: This bit is not used. The initial value is undefined.

Note: Areas below address 0000FF_H not listed in the table are reserved areas. These addresses are accessed by internal access. No access signals are output on the external bus.

MB90650A Series

■ INTERRUPT VECTOR AND INTERRUPT CONTROL REGISTER ASSIGNMENTS TO INTERRUPT SOURCES

Interrupt source	I ² OS support	Interrupt vector		Interrupt control register	
		Number	Address	Number	Address
Reset	×	#08	FFFFDC _H	—	—
INT 9 instruction	×	#09	FFFFD8 _H	—	—
Exception	×	#10	FFFFD4 _H	—	—
A/D converter	○	#11	FFFFD0 _H	ICR00	0000B0 _H
Timebase timer interval interrupt	×	#12	FFFFCC _H		
DTP/external interrupt 0 (External interrupt 0)	○	#13	FFFFC8 _H	ICR01	0000B1 _H
16-bit free-run timer (I/O timer) overflow	○	#14	FFFFC4 _H		
I/O extended serial interface 1	○	#15	FFFFC0 _H	ICR02	0000B2 _H
DTP/external interrupt 1 (External interrupt 1)	○	#16	FFFFBC _H		
I/O extended serial interface 2	○	#17	FFFFB8 _H	ICR03	0000B3 _H
DTP/external interrupt 2 (External interrupt 2)	○	#18	FFFFB4 _H		
DTP/external interrupt 3 (External interrupt 3)	○	#19	FFFFB0 _H	ICR04	0000B4 _H
8/16-bit PPG 0 counter borrow	○	#20	FFFFAC _H		
8/16-bit up/down counter/timer 0 compare	○	#21	FFFFA8 _H	ICR05	0000B5 _H
8/16-bit up/down counter/timer 0 underflow/overflow, up/down invert	○	#22	FFFFA4 _H		
8/16-bit PPG 1 counter borrow	○	#23	FFFFA0 _H	ICR06	0000B6 _H
DTP/external interrupt 4/5 (External interrupt 4/5)	○	#24	FFFF9C _H		
Output compare (channel 2) match (I/O timer)	○	#25	FFFF98 _H	ICR07	0000B7 _H
Output compare (channel 3) match (I/O timer)	○	#26	FFFF94 _H		
Watch prescaler	×	#27	FFFF90 _H	ICR08	0000B8 _H
DTP/external interrupt 6 (External interrupt 6)	○	#28	FFFF8C _H		
8/16-bit up/down counter/timer 1 compare	○	#29	FFFF88 _H	ICR09	0000B9 _H
8/16-bit up/down counter/timer 1 underflow/overflow, up/down invert	○	#30	FFFF84 _H		
Input capture (channel 0) read (I/O timer)	○	#31	FFFF80 _H	ICR10	0000BA _H
Input capture (channel 1) read (I/O timer)	○	#32	FFFF7C _H		
Output compare (channel 0) match (I/O timer)	○	#33	FFFF78 _H	ICR11	0000BB _H
Output compare (channel 1) match (I/O timer)	○	#34	FFFF74 _H		
DTP/external interrupt 7 (External interrupt 7)	○	#36	FFFF6C _H	ICR12	0000BC _H
UART0 receive complete	◎	#37	FFFF68 _H	ICR13	0000BD _H
UART0 transmit complete	◎	#39	FFFF60 _H	ICR14	0000BE _H
I ² C interface	×	#41	FFFF58 _H	ICR15	0000BF _H
Delayed interrupt generation module	×	#42	FFFF54 _H		

○: Indicates that the interrupt request flag is cleared by the I²OS interrupt clear signal.

◎: Indicates that the interrupt request flag is cleared by the I²OS interrupt clear signal (stop request present).

×: Indicates that the interrupt request flag is not cleared by the I²OS interrupt clear signal.

Note: For resources in which two interrupt sources share the same interrupt number, the I²OS interrupt clear signal clears both interrupt request flags.

MB90650A Series

■ PERIPHERAL RESOURCES

1. Parallel Ports

(1) I/O Ports

Each port pin can be specified as either an input or output by its corresponding direction register when the pin is not set for use by a peripheral. When a port is set as an input, reading the data register always reads the value corresponding to the pin level. When a port is set as an output, reading the data register reads the data register latch value. The same applies when reading using a read-modify-write instruction.

When used as control outputs, reading the data register reads the control output value, irrespective of the direction register value.

Note that if a read-modify-write instruction (set bit or similar instruction) is used to set output data in the data register before switching a pin from input to output, the instruction reads the input level at the pin and not the data register latch value.

• Block diagram

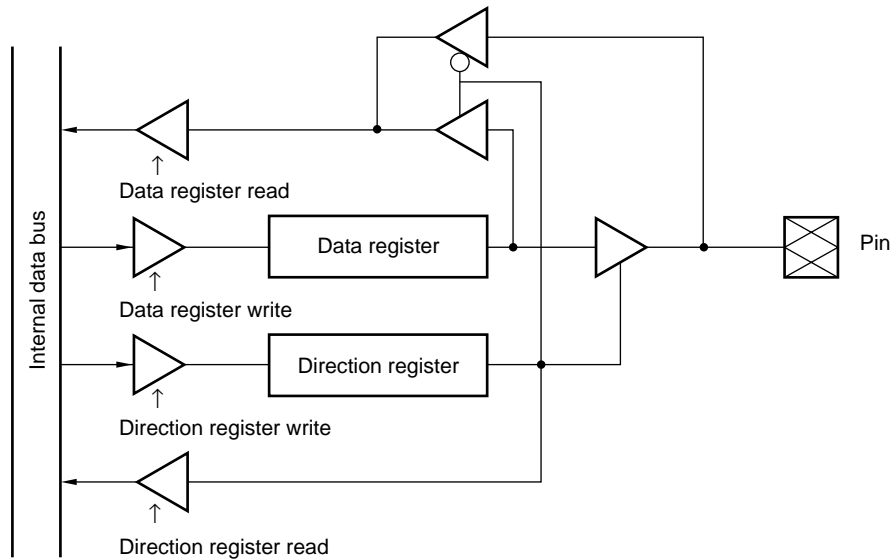

(2) Port Direction Registers

• Port 0 data register (PDR0)

	bit 7	bit 6	bit 5	bit 4	bit 3	bit 2	bit 1	bit 0	Initial value	Access
Address : 000000H	P07	P06	P05	P04	P03	P02	P01	P00	XXXXXXXX _B	R/W*

• Port 1 data register (PDR1)

	bit 15	bit 14	bit 13	bit 12	bit 11	bit 10	bit 9	bit 8	Initial value	Access
Address : 000001H	P17	P16	P15	P14	P13	P12	P11	P10	XXXXXXXX _B	R/W*

• Port 2 data register (PDR2)

	bit 7	bit 6	bit 5	bit 4	bit 3	bit 2	bit 1	bit 0	Initial value	Access
Address : 000002H	P27	P26	P25	P24	P23	P22	P21	P20	XXXXXXXX _B	R/W*

• Port 3 data register (PDR3)

	bit 15	bit 14	bit 13	bit 12	bit 11	bit 10	bit 9	bit 8	Initial value	Access
Address : 000003H	P37	P36	P35	P34	P33	P32	P31	P30	XXXXXXXX _B	R/W*

• Port 4 data register (PDR4)

	bit 7	bit 6	bit 5	bit 4	bit 3	bit 2	bit 1	bit 0	Initial value	Access
Address : 000004H	P47	P46	P45	P44	P43	P42	P41	P40	1XXXXXXXX _B	R/W*

• Port 5 data register (PDR5)

	bit 15	bit 14	bit 13	bit 12	bit 11	bit 10	bit 9	bit 8	Initial value	Access
Address : 000005H	P57	P56	P55	P54	P53	P52	P51	P50	XXXXXXXX _B	R/W*

• Port 6 data register (PDR6)

	bit 7	bit 6	bit 5	bit 4	bit 3	bit 2	bit 1	bit 0	Initial value	Access
Address : 000006H	P67	P66	P65	P64	P63	P62	P61	P60	XXXXXXXX _B	R/W*

• Port 7 data register (PDR7)

	bit 15	bit 14	bit 13	bit 12	bit 11	bit 10	bit 9	bit 8	Initial value	Access
Address : 000007H	—	—	—	P74	P73	P72	P71	P70	--- XX111 _B	R/W*

• Port 8 data register (PDR8)

	bit 7	bit 6	bit 5	bit 4	bit 3	bit 2	bit 1	bit 0	Initial value	Access
Address : 000008H	—	P86	P85	P84	P83	P82	P81	P80	- XXXXXXX _B	R/W*

• Port 9 data register (PDR9)

	bit 15	bit 14	bit 13	bit 12	bit 11	bit 10	bit 9	bit 8	Initial value	Access
Address : 000009H	P97	P96	P95	P94	P93	P92	P91	P90	XXXXXXXX _B	R/W*

• Port A data register (PDRA)

	bit 7	bit 6	bit 5	bit 4	bit 3	bit 2	bit 1	bit 0	Initial value	Access
Address : 00000AH	—	—	—	—	—	PA2	PA1	PA0	----- XXX _B	R/W*

R/W : Readable and writable

— : Unused

X : Indeterminate

* : The operation of reading or writing to I/O ports is slightly different from reading or writing to memory, as follows.

• Input mode

Read: Reads the corresponding pin level.

Write: Writes to the output latch.

• Output mode

Read: Reads the value of the data register latch.

Write: The value is output from the corresponding pin.

MB90650A Series

(3) Port Direction Registers

• Port 0 direction register (DDR0)

Address : 000010 _H	bit 7	bit 6	bit 5	bit 4	bit 3	bit 2	bit 1	bit 0	Initial value	Access
	D07	D06	D05	D04	D03	D02	D01	D00	00000000 _B	R/W*

• Port 1 direction register (DDR1)

Address : 000011 _H	bit 15	bit 14	bit 13	bit 12	bit 11	bit 10	bit 9	bit 8	Initial value	Access
	D17	D16	D15	D14	D13	D12	D11	D10	00000000 _B	R/W*

• Port 2 direction register (DDR2)

Address : 000012 _H	bit 7	bit 6	bit 5	bit 4	bit 3	bit 2	bit 1	bit 0	Initial value	Access
	D27	D26	D25	D24	D23	D22	D21	D20	00000000 _B	R/W*

• Port 3 direction register (DDR3)

Address : 000013 _H	bit 15	bit 14	bit 13	bit 12	bit 11	bit 10	bit 9	bit 8	Initial value	Access
	D37	D36	D35	D34	D33	D32	D31	D30	00000000 _B	R/W*

• Port 4 direction register (DDR4)

Address : 000014 _H	bit 7	bit 6	bit 5	bit 4	bit 3	bit 2	bit 1	bit 0	Initial value	Access
	—	D46	D45	D44	D43	D42	D41	D40	-00000000 _B	R/W*

• Port 5 direction register (DDR5)

Address : 000015 _H	bit 15	bit 14	bit 13	bit 12	bit 11	bit 10	bit 9	bit 8	Initial value	Access
	D57	D56	D55	D54	D53	D52	D51	D50	00000000 _B	R/W*

• Port 6 direction register (DDR6)

Address : 000016 _H	bit 7	bit 6	bit 5	bit 4	bit 3	bit 2	bit 1	bit 0	Initial value	Access
	D67	D66	D65	D64	D63	D62	D61	D60	00000000 _B	R/W*

• Port 7 direction register (DDR7)

Address : 000017 _H	bit 15	bit 14	bit 13	bit 12	bit 11	bit 10	bit 9	bit 8	Initial value	Access
	—	—	—	D74	D73	—	—	—	---00--- _B	R/W*

• Port 8 direction register (DDR8)

Address : 000018 _H	bit 7	bit 6	bit 5	bit 4	bit 3	bit 2	bit 1	bit 0	Initial value	Access
	—	D86	D85	D84	D83	D82	D81	D80	-00000000 _B	R/W*

• Port 9 direction register (DDR9)

Address : 000019 _H	bit 15	bit 14	bit 13	bit 12	bit 11	bit 10	bit 9	bit 8	Initial value	Access
	D97	D96	D95	D94	D93	D92	D91	D90	00000000 _B	R/W*

• Port A direction register (DDRA)

Address : 00001A _H	bit 7	bit 6	bit 5	bit 4	bit 3	bit 2	bit 1	bit 0	Initial value	Access
	—	—	—	—	—	DA2	DA1	DA0	-----000 _B	R/W*

R/W : Readable and writable
 — : Unused

(Continued)

(Continued)

* : The operation of reading or writing to I/O ports is slightly different from reading or writing to memory, as follows.

- Input mode
Read: Reads the corresponding pin level.
Write: Writes to the output latch.
- Output mode
Read: Reads the value of the data register latch.
Write: The value is output from the corresponding pin.

When pins are used as ports, the register bits control the corresponding pins as follows.

0: Input mode

1: Output mode

Bits are set to "0" by a reset.

- P47, P70 to P72

No DDR for this port. Data is always available in this port, so when using P70 and P71 as I²C pin, set PDR value to "1". (Otherwise when using P70 and P71 by themselves, turn off the I²C.)

As this port is open-drain output style, so when using this port as an input port, in order to turn off the output transistor, set the output data register value to "1" and add the pull up resistor to the external pin.

MB90650A Series

(4) Port Resistance Registers

• Register configuration

• Port 0 resistance register (RDR0)

Address : 00001C _H	bit 7	bit 6	bit 5	bit 4	bit 3	bit 2	bit 1	bit 0	Initial value	Access
	RD07	RD06	RD05	RD04	RD03	RD02	RD01	RD00	00000000 _B	R/W

• Port 1 resistance register (RDR1)

Address : 00001D _H	bit 15	bit 14	bit 13	bit 12	bit 11	bit 10	bit 9	bit 8	Initial value	Access
	RD17	RD16	RD15	RD14	RD13	RD12	RD11	RD10	00000000 _B	R/W

• Port 6 resistance register (RDR6)

Address : 00001E _H	bit 7	bit 6	bit 5	bit 4	bit 3	bit 2	bit 1	bit 0	Initial value	Access
	RD67	RD66	RD65	RD64	RD63	RD62	RD61	RD60	00000000 _B	R/W

R/W : Readable and writable

• Block diagram

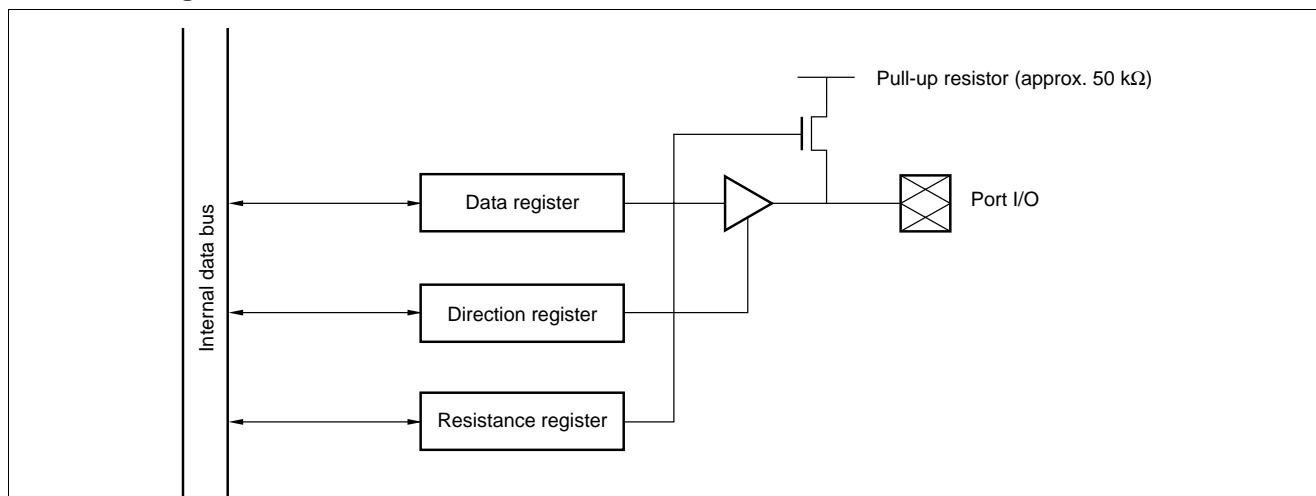

Notes: • Input resistance register R/W

Controls the pull-up resistor in input mode.

0: Pull-up resistor disconnected in input mode.

1: Pull-up resistor connected in input mode.

The setting has no meaning in output mode (pull-up resistor disconnected).

The direction register (DDR) sets input or output mode.

• The pull-up resistor is disconnected in hardware standby or stop mode (SPL = 1) (high impedance).

• This function is disabled when using an external bus mode. In this case, do not write to this register.

(5) Port Pin Register**• Register configuration****• Port 4 pin register (ODR4)**

	bit 7	bit 6	bit 5	bit 4	bit 3	bit 2	bit 1	bit 0	Initial value	Access
Address : 00001B _H	—	OD46	OD45	OD44	OD43	OD42	OD41	OD40	-0000000 _B	R/W

R/W : Readable and writable
 — : Unused

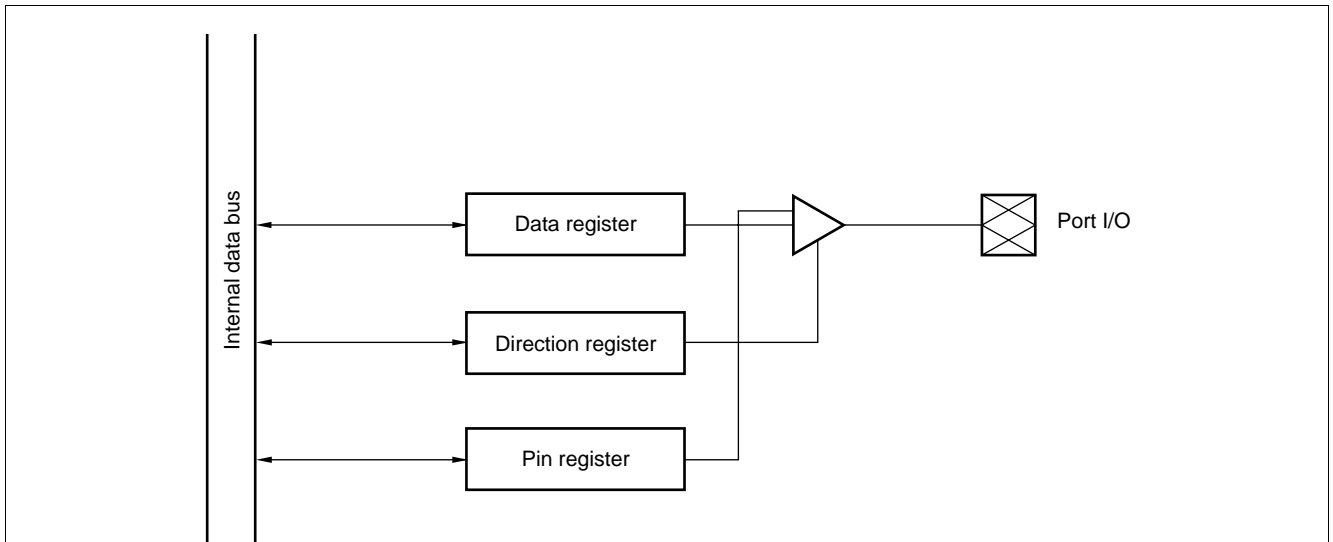
• Block diagram**Notes:** • Pin register R/W

Performs open-drain control in output mode.

0: Operate as a standard output port in output mode.

1: Operate as an open-drain output port in output mode.

The setting has no meaning in input mode (output Hi-z).

The direction register (DDR) sets input or output mode.

- This function is disabled when using an external bus mode. In this case, do not write to this register.

(6) Analog Input Enable Register**• Register configuration****• Analog input enable register (ADER)**

	bit 15	bit 14	bit 13	bit 12	bit 11	bit 10	bit 9	bit 8	Initial value	Access
Address : 00001F _H	ADE7	ADE6	ADE5	ADE4	ADE3	ADE2	ADE1	ADE0	11111111 _B	R/W

R/W : Readable and writable

Controls each port 5 pin as follows.

0: Port input mode

1: Analog input mode

Set to "1" by a reset.

MB90650A Series

2. UART

The UART is a serial I/O port that can be used for CLK asynchronous (start-stop synchronization) or CLK synchronous communications. The UART has the following features.

- Full duplex, double buffered
- Supports asynchronous (start-stop synchronization) and CLK synchronous data transfer
- Supports multi-processor mode
- Built-in dedicated baud rate generator

Asynchronous : 9615 bps, 31250 bps, 4808 bps, 2404 bps and 1202 bps
 CLK synchronous : 1 Mbps, 500 kbps, 250 kbps, 125 kbps, 115.2 kbps and 62.5 kbps } For a 6, 8, 10, 12, or 16 MHz clock.

- Supports flexible baud rate setting using an external clock
- Error detect function (parity, framing, and overrun)
- NRZ type transmission signal
- Intelligent I/O service support

(1) Register Configuration

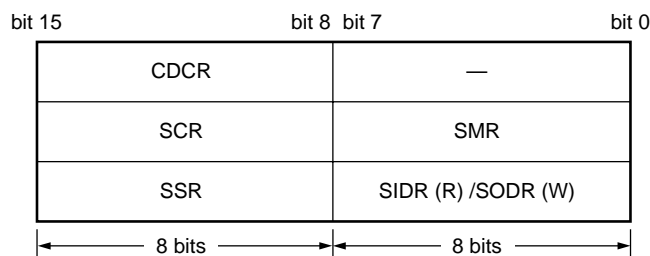

• Serial mode register 0 (SMR0)

Address : 000020H	bit 7	bit 6	bit 5	bit 4	bit 3	bit 2	bit 1	bit 0	Initial value
	MD1	MD0	CS2	CS1	CS0	Reserved	SCKE	SOE	0000000 _B
	R/W	R/W	R/W	R/W	R/W	R/W	R/W	R/W	

• Serial control register 0 (SCR0)

Address : 000021H	bit 15	bit 14	bit 13	bit 12	bit 11	bit 10	bit 9	bit 8	Initial value
	PEN	P	SBL	CL	A/D	REC	RXE	TXE	00000100 _B
	R/W	R/W	R/W	R/W	R/W	R/W	R/W	R/W	

• Serial input register/serial output register 0 (SIDR/SODR0)

Address : 000022H	bit 7	bit 6	bit 5	bit 4	bit 3	bit 2	bit 1	bit 0	Initial value
	D7	D6	D5	D4	D3	D2	D1	D0	XXXXXXXX _B
	R/W	R/W	R/W	R/W	R/W	R/W	R/W	R/W	

• Serial status register 0 (SSR0)

Address : 000023H	bit 15	bit 14	bit 13	bit 12	bit 11	bit 10	bit 9	bit 8	Initial value
	PE	ORE	FRE	RDRF	TDRE	—	RIE	TIE	00001-00 _B
	R	R	R	R	R	—	R/W	R/W	

• Clock division control register (CDCR)

Address : 000027H	bit 15	bit 14	bit 13	bit 12	bit 11	bit 10	bit 9	bit 8	Initial value
	MD	—	—	—	DIV3	DIV2	DIV1	DIV0	0---1111 _B
	R/W	—	—	—	R/W	R/W	R/W	R/W	

R/W : Readable and writable
 R : Read only
 W : Write only
 — : Unused
 X : Indeterminate

MB90650A Series

(2) Block Diagram

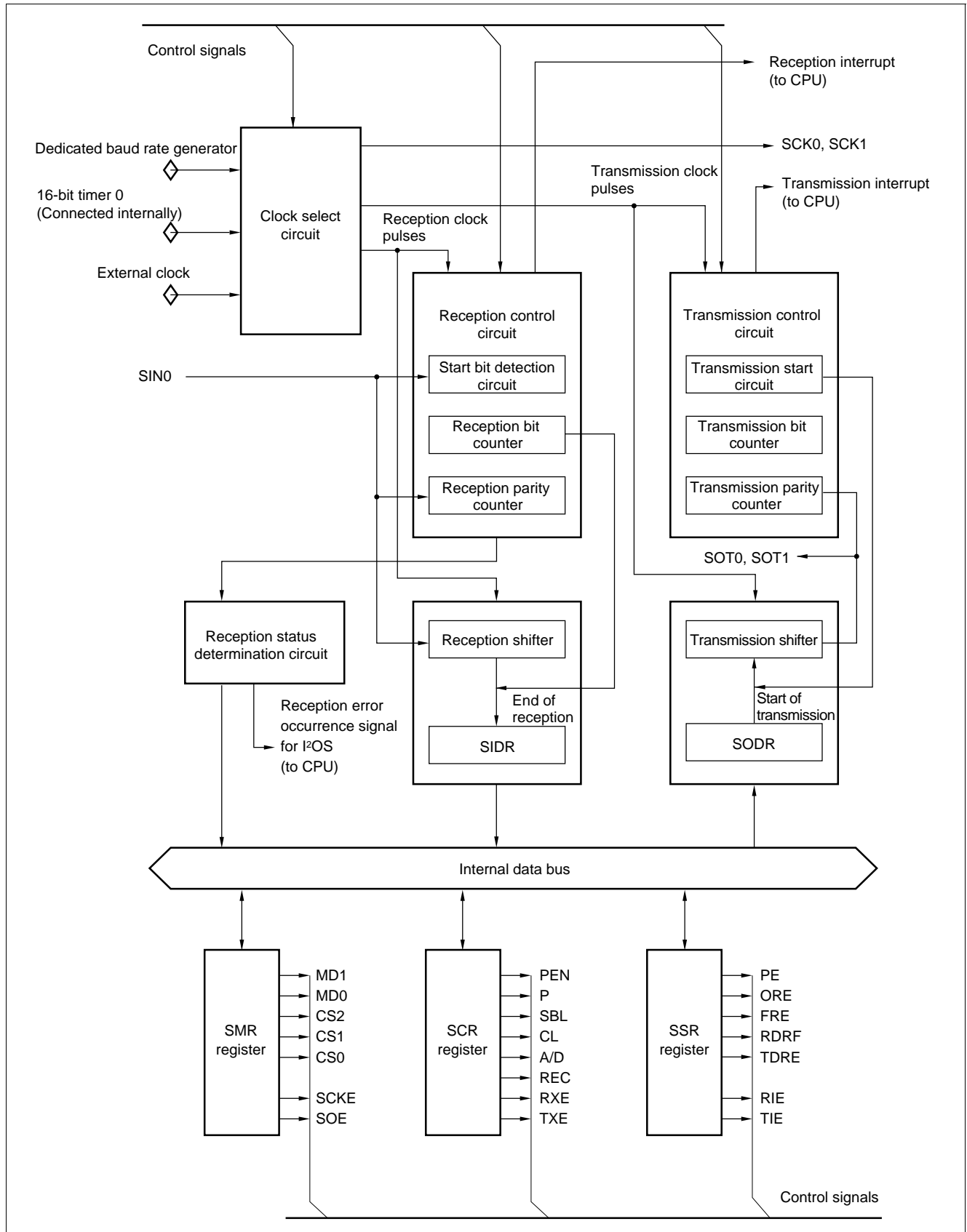

MB90650A Series

3. I/O Extended Serial Interface

I/O extended serial interface consists of an 8-bit serial I/O interface that can perform clock synchronous data transfer. Either LSB-first or MSB-first data transfer can be selected.

The following two serial I/O operation modes are available.

- Internal shift clock mode: Data transfer is synchronized with the internal clock.
- External shift clock mode: Data transfer is synchronized with the clock input from the external pin (SCK). By manipulating the general-purpose port that shares the external pin (SCK), this mode also enables the data transfer operation to be driven by CPU instructions.

(1) Register Details

• Serial mode control status register 0, 1 (SMCS0, SMCS1)

Address : 000025H 000029H	bit 15	bit 14	bit 13	bit 12	bit 11	bit 10	bit 9	bit 8	Initial value 00000010 _B
	SMD2	SMD1	SMD0	SIE	SIR	BUSY	STOP	STRT	
	R/W	R/W	R/W	R/W	R/W ^{*1}	R	R/W	R/W ^{*2}	
Address : 000024H 000028H	bit 7	bit 6	bit 5	bit 4	bit 3	bit 2	bit 1	bit 0	Initial value ----0000 _B
	—	—	—	—	MODE	BDS	SOE	SCOE	
	—	—	—	—	R/W	R/W	R/W	R/W	

• Serial data register 0, 1 (SDR0, SDR1)

Address : 000026H 00002AH	bit 7	bit 6	bit 5	bit 4	bit 3	bit 2	bit 1	bit 0	Initial value XXXXXXXX _B
	D7	D6	D5	D4	D3	D2	D1	D0	
	R/W	R/W	R/W	R/W	R/W	R/W	R/W	R/W	

R/W : Readable and writable
 R : Read only
 — : Unused
 X : Indeterminate

*1: Only "0" can be written.

*2: Only "1" can be written. Reading always returns "0".

This register controls the transfer operation mode of the serial I/O. The following describes the function of each bit.

bit 3: Serial mode selection bit (MODE)

This bit selects the conditions for starting operation from the halted state. Changing the mode during operation is prohibited

MODE	Operation
0	Start when STRT is set to "1". [Initial value]
1	Start on reading from or writing to the serial data register.

The bit is initialized to "0" by a reset. The bit is readable and writable. Set to "1" when using the intelligent I/O service.

bit 2: Transfer direction selection bit (BDS: Bit Direction Select)

Selects as follows at the time of serial data input and output whether the data are to be transferred in the order from LSB to MSB or vice versa.

MODE	Operation
0	LSB-first [Initial value]
1	MSB-first

MB90650A Series

(2) Block Diagram

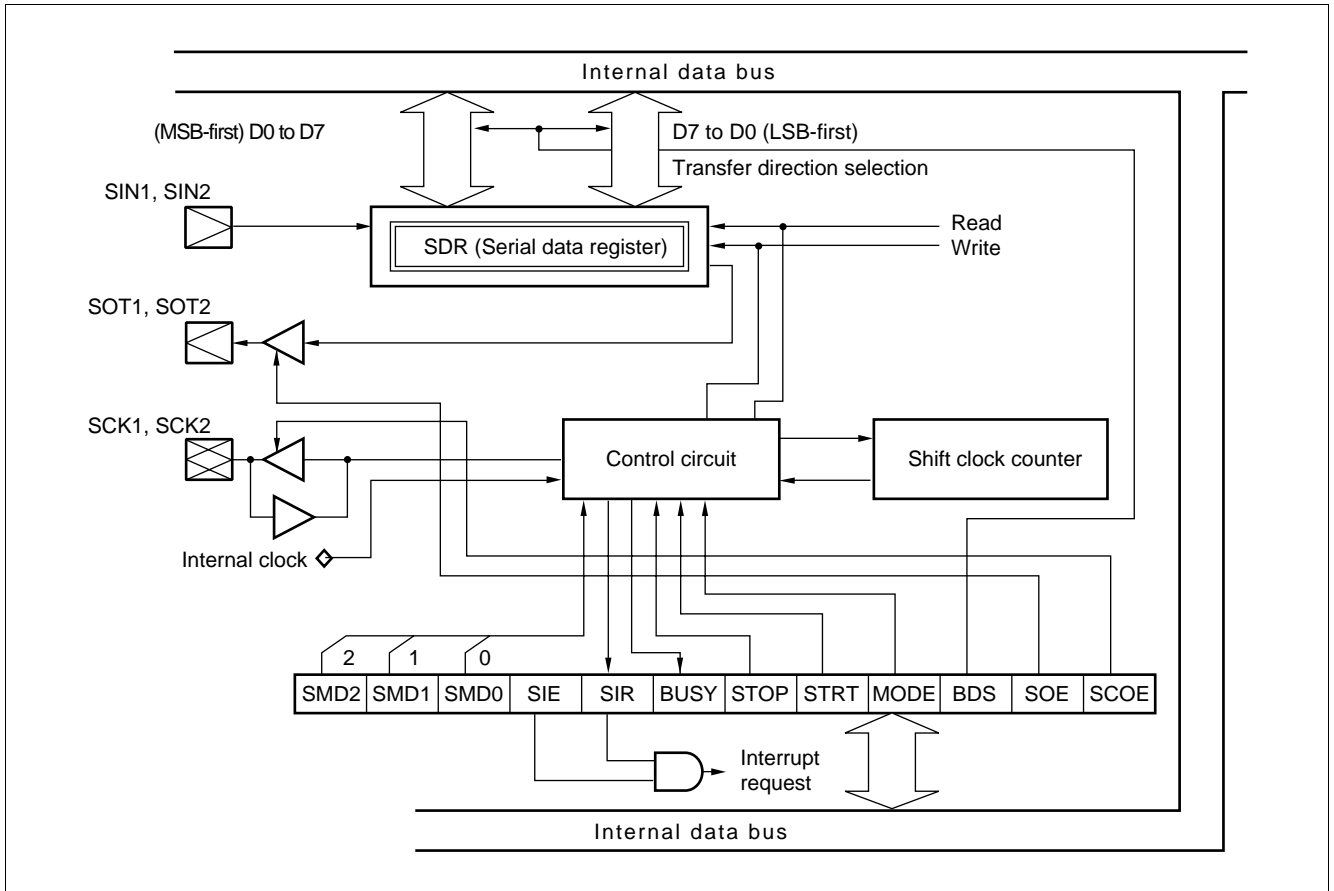

MB90650A Series

4. A/D Converter

The A/D converter converts analog input voltages to digital values. The A/D converter has the following features.

- Conversion time: Minimum of 5.2 μ s per channel (for a 16 MHz machine clock)
- Uses RC-type successive approximation conversion with a sample and hold circuit.
- 10-bit resolution
- Eight program-selectable analog input channels
 - Single conversion mode: Selectively convert a one channel.
 - Scan conversion mode: Continuously convert multiple channels. Maximum of 8 program-selectable channels.
 - Continuous conversion mode : Repeatedly convert specified channels.
 - Stop conversion mode: Convert one channel then halt until the next activation. (Enables synchronization of the conversion start timing.)
- An A/D conversion completion interrupt request to the CPU can be generated on the completion of A/D conversion. This interrupt can activate I²OS to transfer the result of A/D conversion to memory and is suitable for continuous operation.
- Activation by software, external trigger (falling edge), or timer (rising edge) can be selected.

(1) Register Configuration

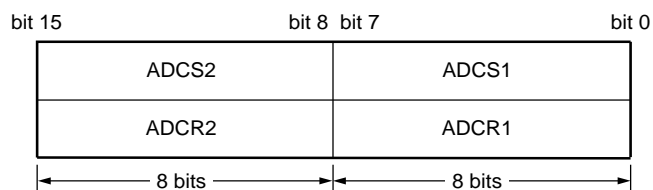

• Control status register 1 (ADCS1)

	bit 7	bit 6	bit 5	bit 4	bit 3	bit 2	bit 1	bit 0	Initial value
Address : 000036H	MD1	MD0	ANS2	ANS1	ANS0	ANE2	ANE1	ANE0	00000000 _B
	R/W	R/W	R/W	R/W	R/W	R/W	R/W	R/W	

• Control status register 2 (ADCS2)

	bit 15	bit 14	bit 13	bit 12	bit 11	bit 10	bit 9	bit 8	Initial value
Address : 000037H	BUSY	INT	INTE	PAUS	STS1	STS0	STRT	DA	00000000 _B
	R/W	R/W	R/W	R/W	R/W	R/W	R/W	R/W	

• Data register 1 (ADCR1)

	bit 7	bit 6	bit 5	bit 4	bit 3	bit 2	bit 1	bit 0	Initial value
Address : 000038H	7	6	5	4	3	2	1	0	XXXXXXXX _B
	R	R	R	R	R	R	R	R	

• Data register 2 (ADCR2)

	bit 15	bit 14	bit 13	bit 12	bit 11	bit 10	bit 9	bit 8	Initial value
Address : 000039H	—	—	—	—	—	—	9	8	XXXXXXXX _B
	R	R	R	R	R	R	R	R	

R/W : Readable and writable
 R : Read only
 X : Indeterminate

MB90650A Series

(2) Block Diagram

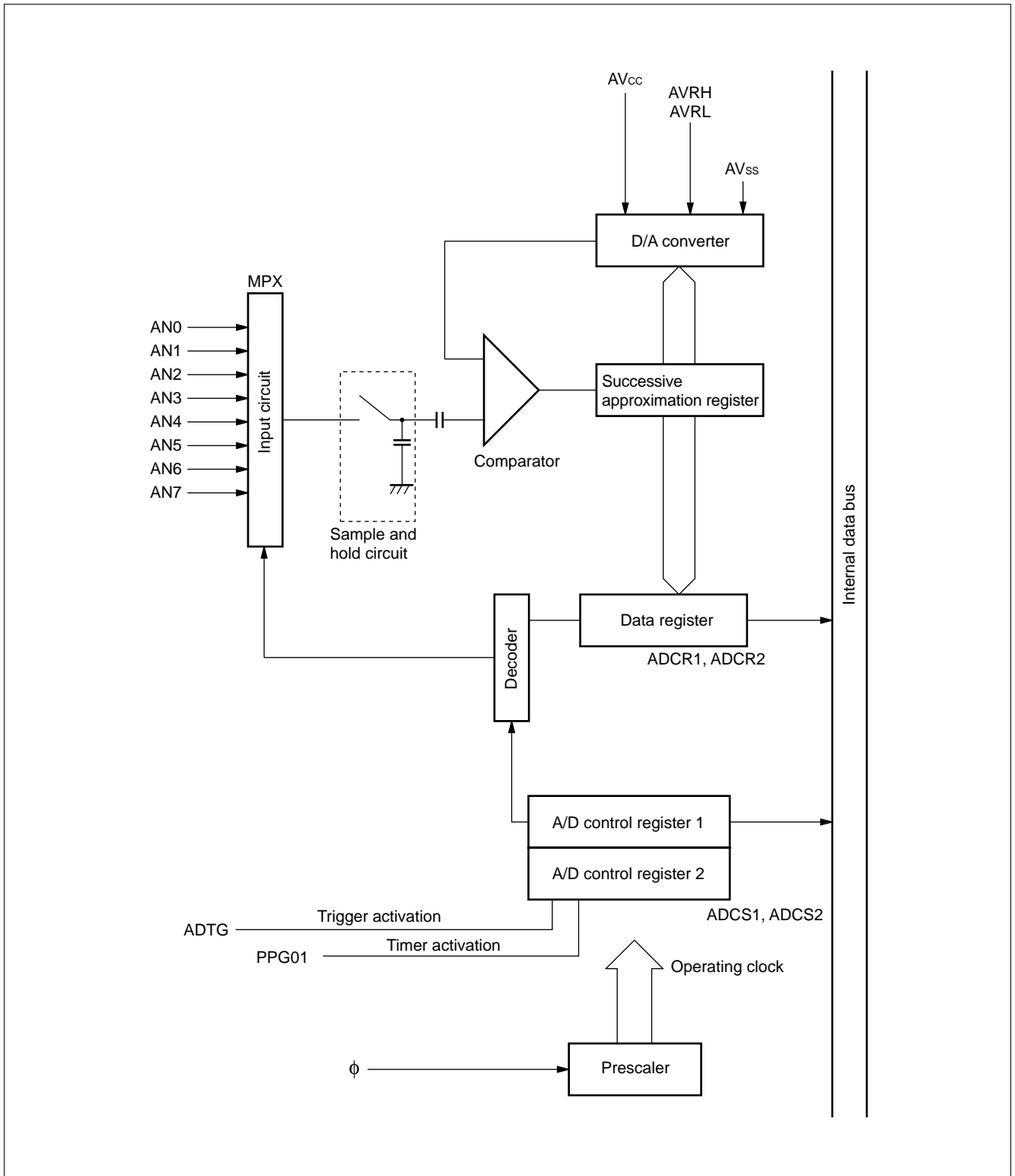

MB90650A Series

5. D/A Converter

D/A converter is an R-2R type D/A converter with 8-bit resolution. The device contains two D/A converters. The D/A control register controls the output of the two D/A converters independently.

(1) Register Configuration

• D/A converter data register 0 (DAT0)									
	bit 7	bit 6	bit 5	bit 4	bit 3	bit 2	bit 1	bit 0	Initial value
Address : 00003A _H	DA07	DA06	DA05	DA04	DA03	DA02	DA01	DA00	XXXXXXXX _B
• D/A converter data register 1 (DAT1)									
	R/W	R/W	R/W	R/W	R/W	R/W	R/W	R/W	Initial value
	bit 15	bit 14	bit 13	bit 12	bit 11	bit 10	bit 9	bit 8	Initial value
Address : 00003B _H	DA17	DA16	DA15	DA14	DA13	DA12	DA11	DA10	XXXXXXXX _B
• D/A control register channel 0 (DACR0)									
	R/W	R/W	R/W	R/W	R/W	R/W	R/W	R/W	Initial value
	bit 7	bit 6	bit 5	bit 4	bit 3	bit 2	bit 1	bit 0	Initial value
Address : 00003C _H	—	—	—	—	—	—	—	DAE0	-----0 _B
• D/A control register channel 1 (DACR1)									
	—	—	—	—	—	—	—	R/W	Initial value
	bit 15	bit 14	bit 13	bit 12	bit 11	bit 10	bit 9	bit 8	Initial value
Address : 00003D _H	—	—	—	—	—	—	—	DAE1	-----0 _B
	—	—	—	—	—	—	—	R/W	
R/W : Readable and writable									
— : Unused									
X : Indeterminate									

MB90650A Series

(2) Block Diagram

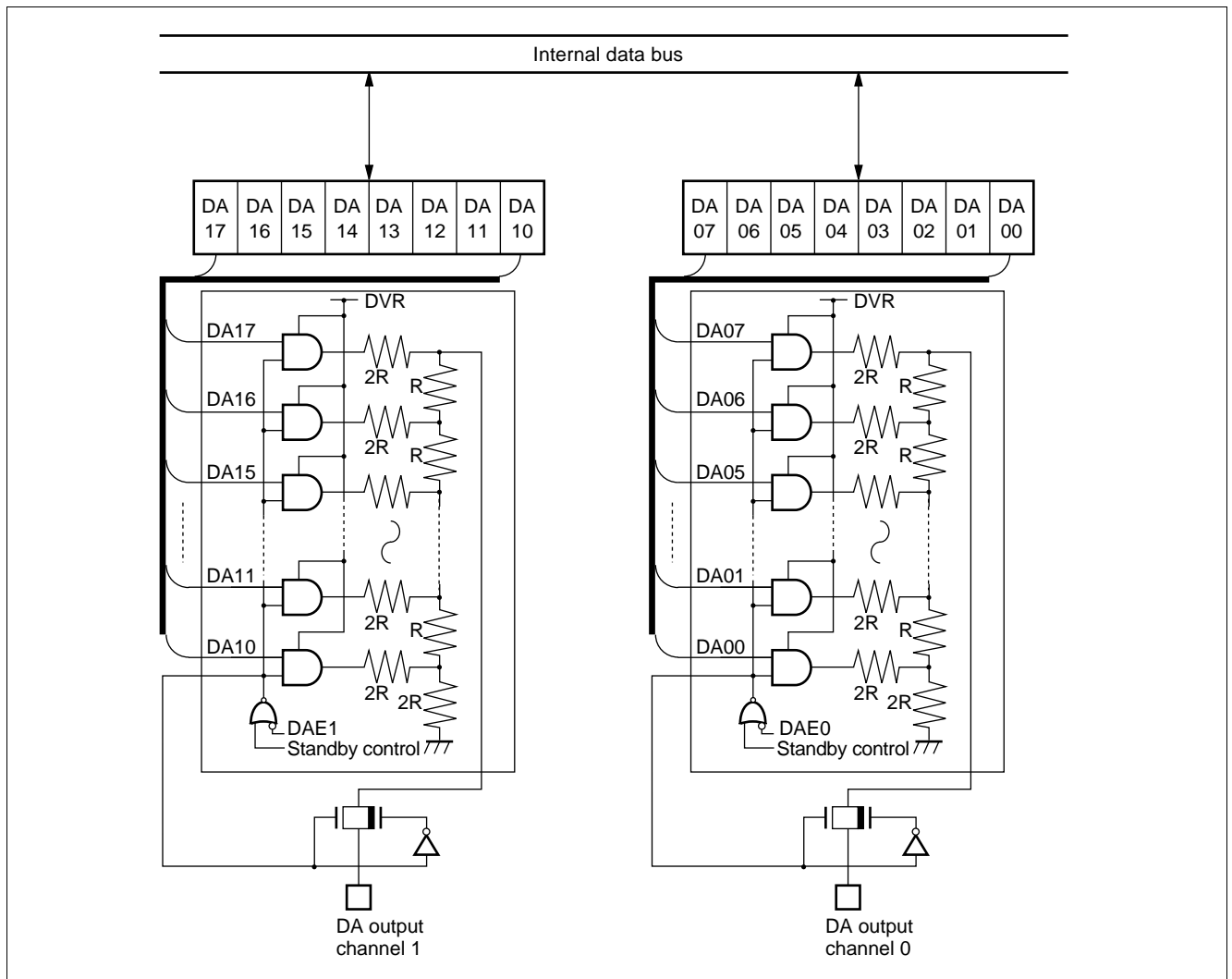

MB90650A Series

6. 8/16-bit PPG

8/16-bit PPG is an 8-bit reload timer module. The block performs PPG output in which the pulse output is controlled by the operation of the timer.

The hardware consists of two 8-bit down-counters, four 8-bit reload registers, one 16-bit control register, two external pulse output pins, and two interrupt outputs. The PPG has the following functions.

- 8-bit PPG output in two channels independent operation mode:
Two independent PPG output channels are available.
- 16-bit PPG output operation mode : One 16-bit PPG output channel is available.
- 8 + 8-bit PPG output operation mode : Variable-period 8-bit PPG output operation is available by using the output of channel 0 as the clock input to channel 1.
- PPG output operation : Outputs pulse waveforms with variable period and duty ratio. Can be used as a D/A converter in conjunction with an external circuit.

(1) Register Configuration

• PPG0 operation mode control register channel 0 (PPGC0)

	bit 7	bit 6	bit 5	bit 4	bit 3	bit 2	bit 1	bit 0	Initial value
Address : 000044 _H	PEN0	—	PE00	PIE0	PUF0	—	—	Reserved	0X000XX1 _B
	R/W	—	R/W	R/W	R/W	—	—	—	

• PPG1 operation mode control register channel 1 (PPGC1)

	bit 15	bit 14	bit 13	bit 12	bit 11	bit 10	bit 9	bit 8	Initial value
Address : 000045 _H	PEN1	—	PE10	PIE1	PUF1	MD1	MD0	Reserved	0X000001 _B
	R/W	—	R/W	R/W	R/W	R/W	R/W	—	

• PPG0, PPG1 output control register channel 0, channel 1 (PPGOE)

	bit 7	bit 6	bit 5	bit 4	bit 3	bit 2	bit 1	bit 0	Initial value
Address : 000046 _H	PCS2	PCS1	PCS0	PCM2	PCM1	PCM0	PE11	PE01	00000000 _B
	R/W	R/W	R/W	R/W	R/W	R/W	R/W	R/W	

• Reload register upper channel 0, channel 1 (PRLH0, PRLH1)

	bit 15	bit 14	bit 13	bit 12	bit 11	bit 10	bit 9	bit 8	Initial value
Address : 000041 _H 000043 _H									XXXXXXXX _B
	R/W	R/W	R/W	R/W	R/W	R/W	R/W	R/W	

• Reload register lower channel 0, channel 1 (PRL0, PRL1)

	bit 7	bit 6	bit 5	bit 4	bit 3	bit 2	bit 1	bit 0	Initial value
Address : 000040 _H 000042 _H									XXXXXXXX _B
	R/W	R/W	R/W	R/W	R/W	R/W	R/W	R/W	

R/W : Readable and writable
X : Indeterminate

MB90650A Series

(2) Block Diagram

• 8/16-bit PPG (channel 0)

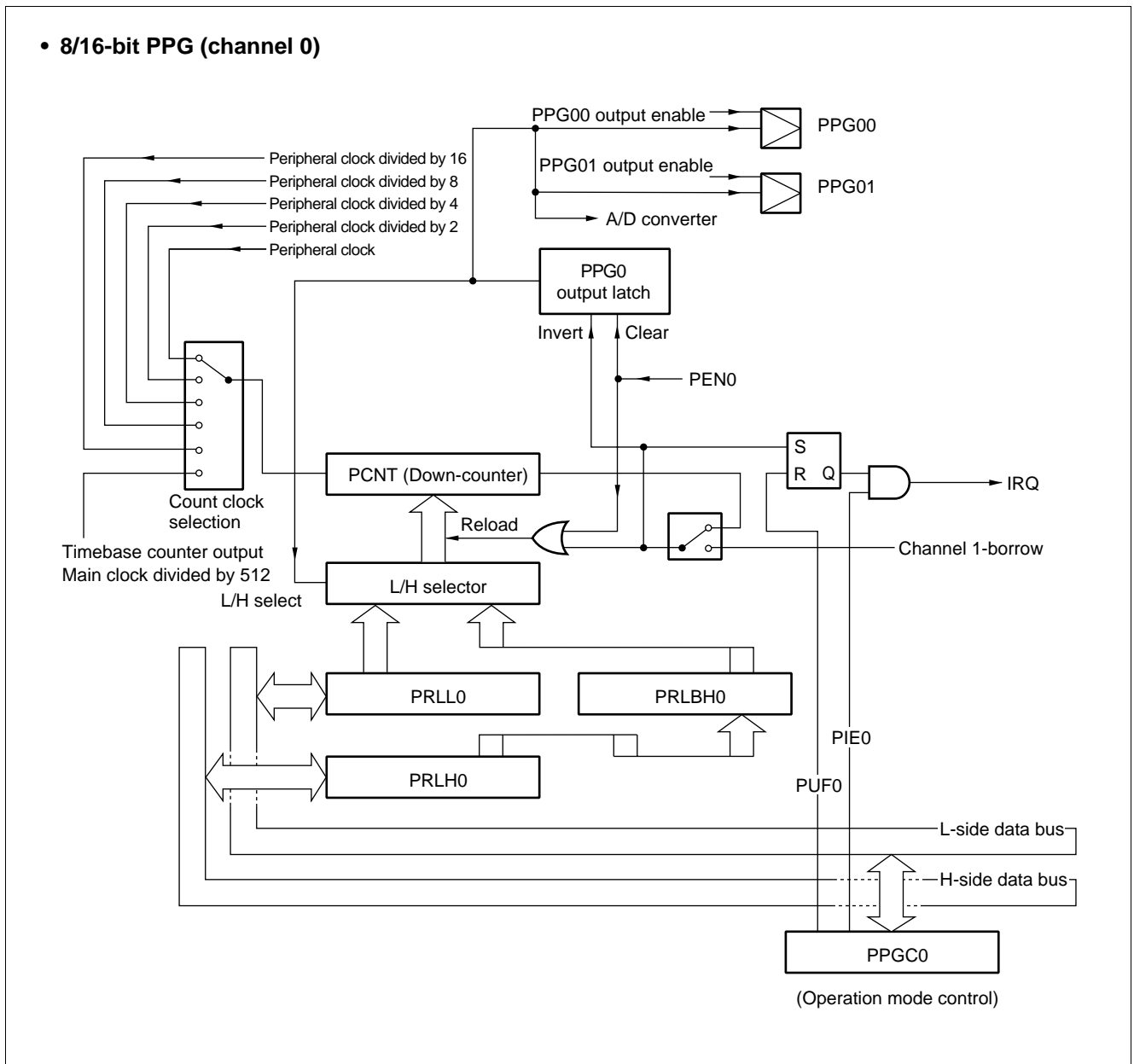

MB90650A Series

• 8/16-bit PPG (channel 1)

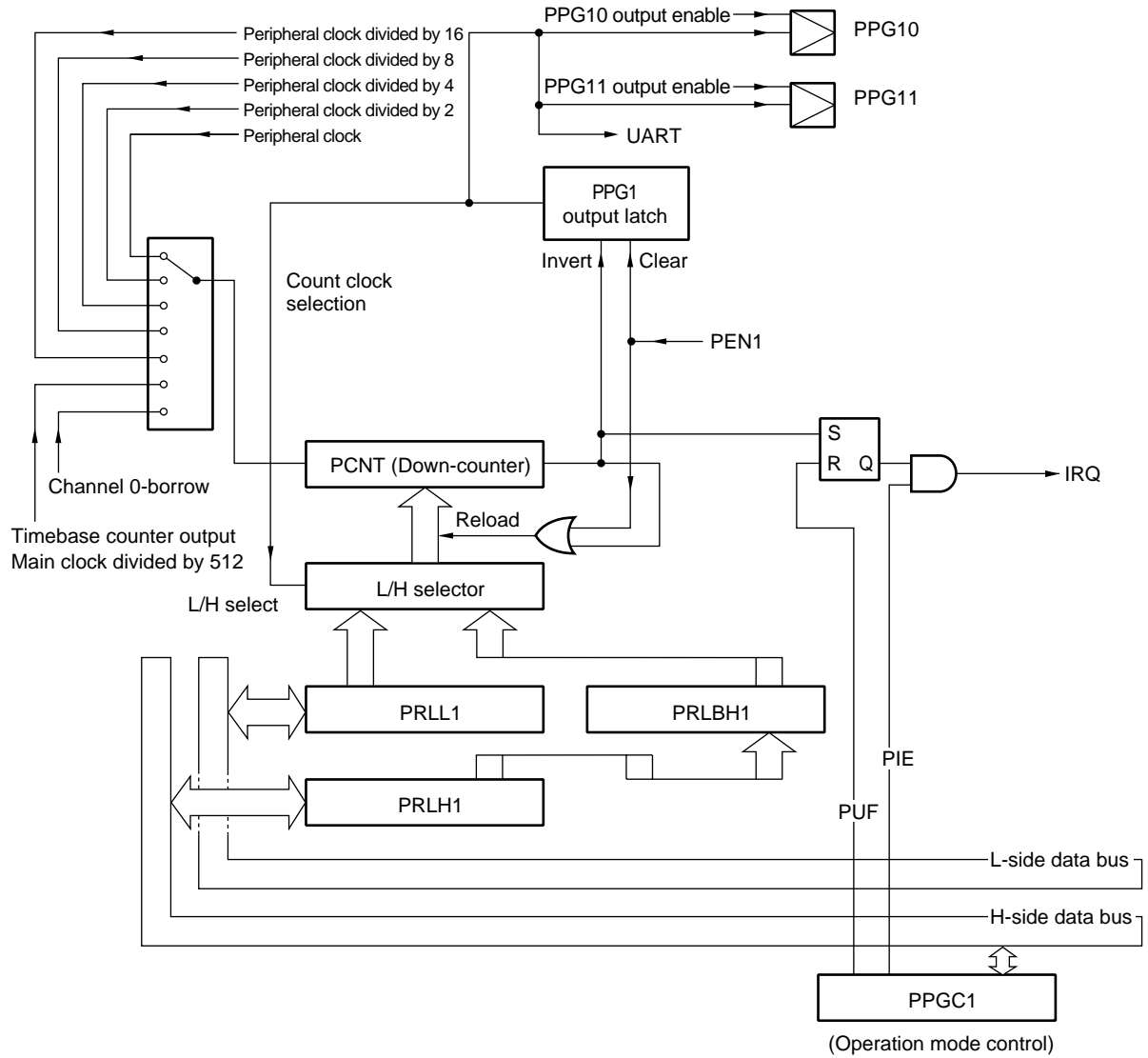

7. 8/16-bit Up/Down Counter/Timer

8/16-bit up/down counter/timer is an up/down counter/timer and consists of six event input pins, two 8-bit up/down counters, two 8-bit reload/compare registers, and their control circuits.

(1) Main Functions

- The 8-bit count register can count in the range 0 to 256 (or 0 to 65535 in 1 × 16-bit operation mode).
- The count clock selection can select between four different count modes.

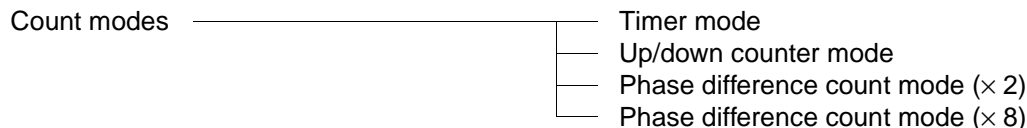

- Two different internal count clocks are available in timer mode.

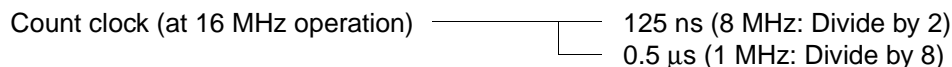

- In up/down count mode, you can select which edge to detect on the external pin input signal.

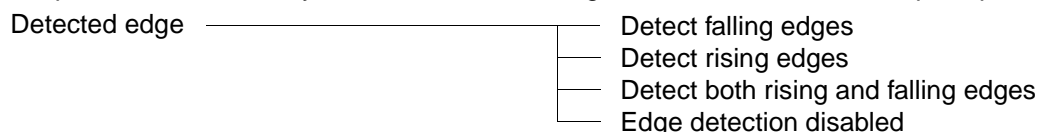

- Phase difference count mode is suitable for motor encoder counting. By inputting the A, B, and Z phase outputs from the encoder, a high-precision rotational angle, speed, or similar count can be implemented simply.
- Two different functions can be selected for the ZIN pin.

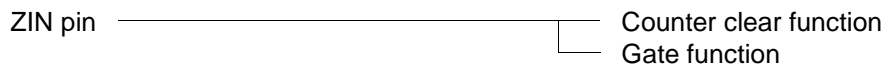

- Compare and reload functions are available and can be used either independently or together. A variable-width up/down count can be performed by activating both functions.

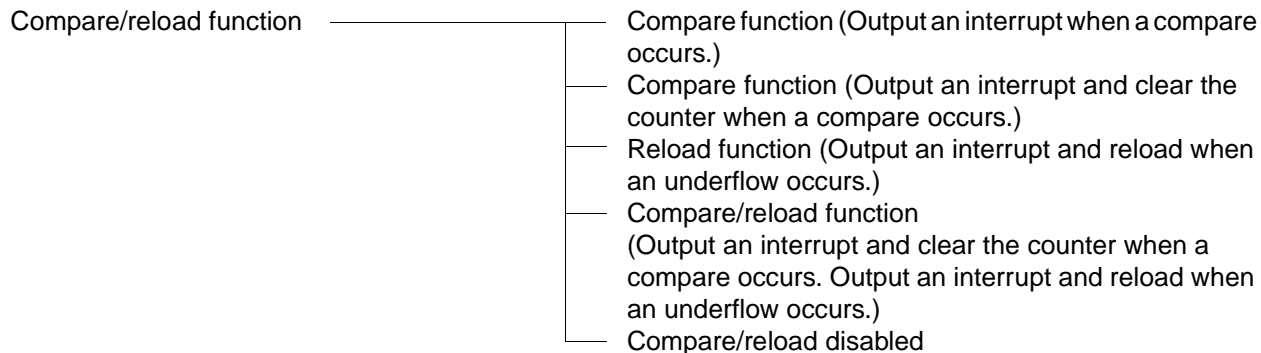

- Whether or not to generate an interrupt when a compare, reload (underflow), or overflow occurs can be set independently.
- The previous count direction can be determined from the count direction flag.
- An interrupt can be generated when the count direction changes.

MB90650A Series

(2) Register Configuration

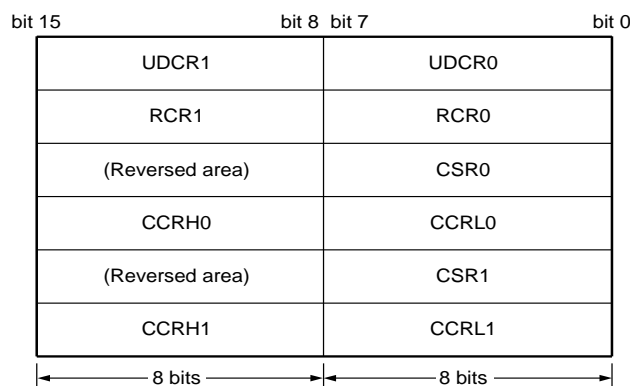

- Up/down count register channel 0 (UDCR0)

Address : 000070H	bit 7	bit 6	bit 5	bit 4	bit 3	bit 2	bit 1	bit 0	Initial value
	D07	D06	D05	D04	D03	D02	D01	D00	00000000 _B
	R	R	R	R	R	R	R	R	

- Up/down count register channel 1 (UDCR1)

Address : 000071H	bit 15	bit 14	bit 13	bit 12	bit 11	bit 10	bit 9	bit 8	Initial value
	D17	D16	D15	D14	D13	D12	D11	D10	00000000 _B
	R	R	R	R	R	R	R	R	

- Reload compare register channel 0 (RCR0)

Address : 000072H	bit 7	bit 6	bit 5	bit 4	bit 3	bit 2	bit 1	bit 0	Initial value
	D07	D06	D05	D04	D03	D02	D01	D00	00000000 _B
	W	W	W	W	W	W	W	W	

- Reload compare register channel 1 (RCR1)

Address : 000073H	bit 15	bit 14	bit 13	bit 12	bit 11	bit 10	bit 9	bit 8	Initial value
	D17	D16	D15	D14	D13	D12	D11	D10	00000000 _B
	W	W	W	W	W	W	W	W	

- Counter status register channel 0, channel 1 (CSR0, CSR1)

Address : 000074H 000078H	bit 7	bit 6	bit 5	bit 4	bit 3	bit 2	bit 1	bit 0	Initial value
	CSTR	CITE	UDIE	CMPF	OVFF	UDFF	UDF1	UDF0	00000000 _B
	R/W	R/W	R/W	R/W	R/W	R/W	R	R	

- Counter control register channel 0, channel 1 (CCRL0, CCRL1)

Address : 000076H 00007AH	bit 7	bit 6	bit 5	bit 4	bit 3	bit 2	bit 1	bit 0	Initial value
	—	CTUT	UCRE	RLDE	UDCC	CGSC	CGE1	CGE0	00010000 _B 00000000 _B
	—	R/W	R/W	R/W	R/W	R/W	R/W	R/W	

- Counter control register channel 0 (CCRH0)

Address : 000077H	bit 15	bit 14	bit 13	bit 12	bit 11	bit 10	bit 9	bit 8	Initial value
	M16E	CDCF	CFIE	CLKS	CMS1	CMS0	CES1	CES0	00000000 _B
	R/W	R/W	R/W	R/W	R/W	R/W	R/W	R/W	

- Counter control register channel 1 (CCRH1)

Address : 00007BH	bit 15	bit 14	bit 13	bit 12	bit 11	bit 10	bit 9	bit 8	Initial value
	—	CDCF	CFIE	CLKS	CMS1	CMS0	CES1	CES0	X0001000 _B
	—	R/W	R/W	R/W	R/W	R/W	R/W	R/W	

R/W : Readable and writable
 R : Read only
 W : Write only
 — : Unused
 X : Indeterminate

(3) Block Diagram

• 8/16-bit up/down counter/timer (channel 0)

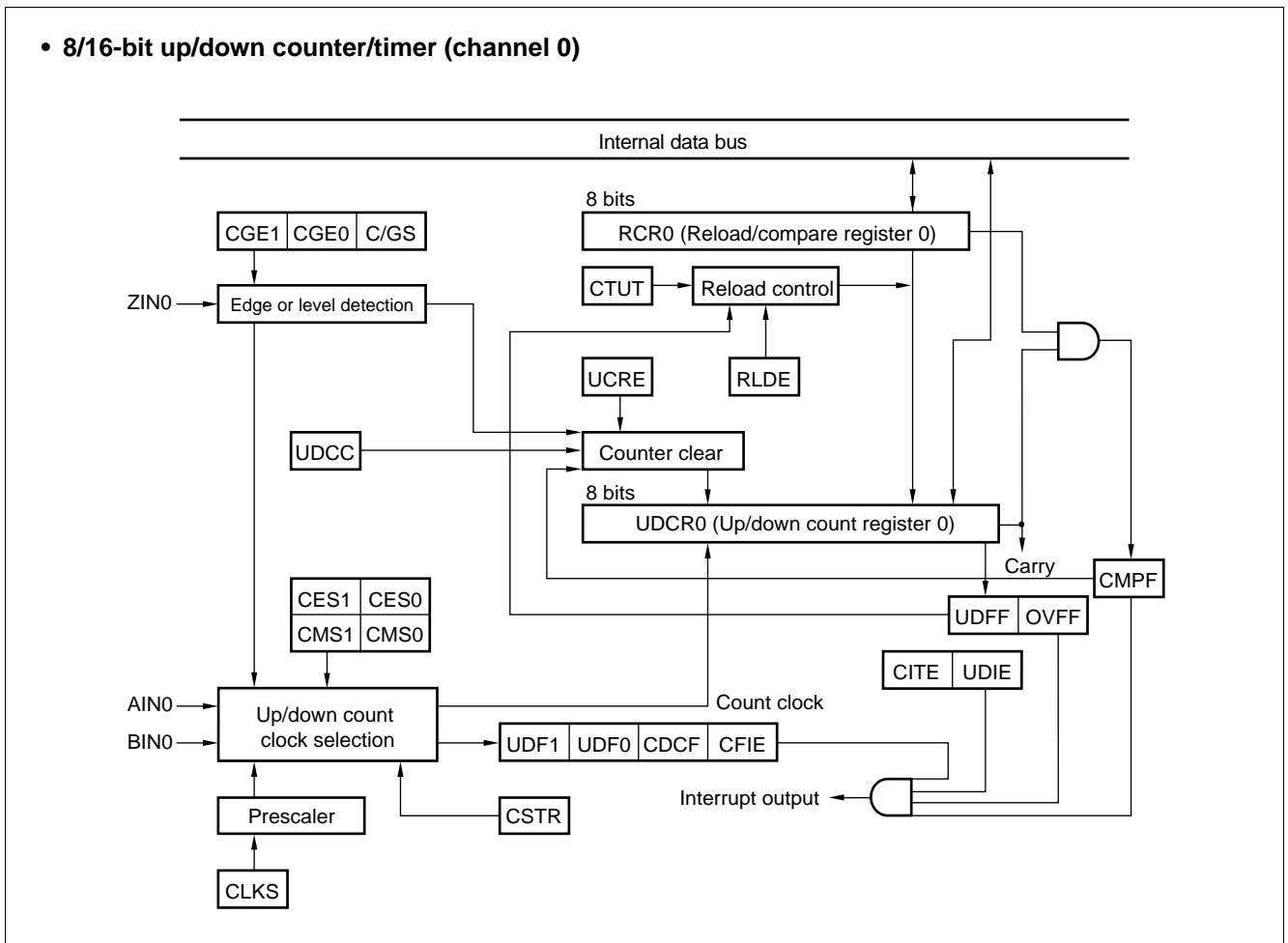

MB90650A Series

• 8/16-bit up/down counter/timer (channel 1)

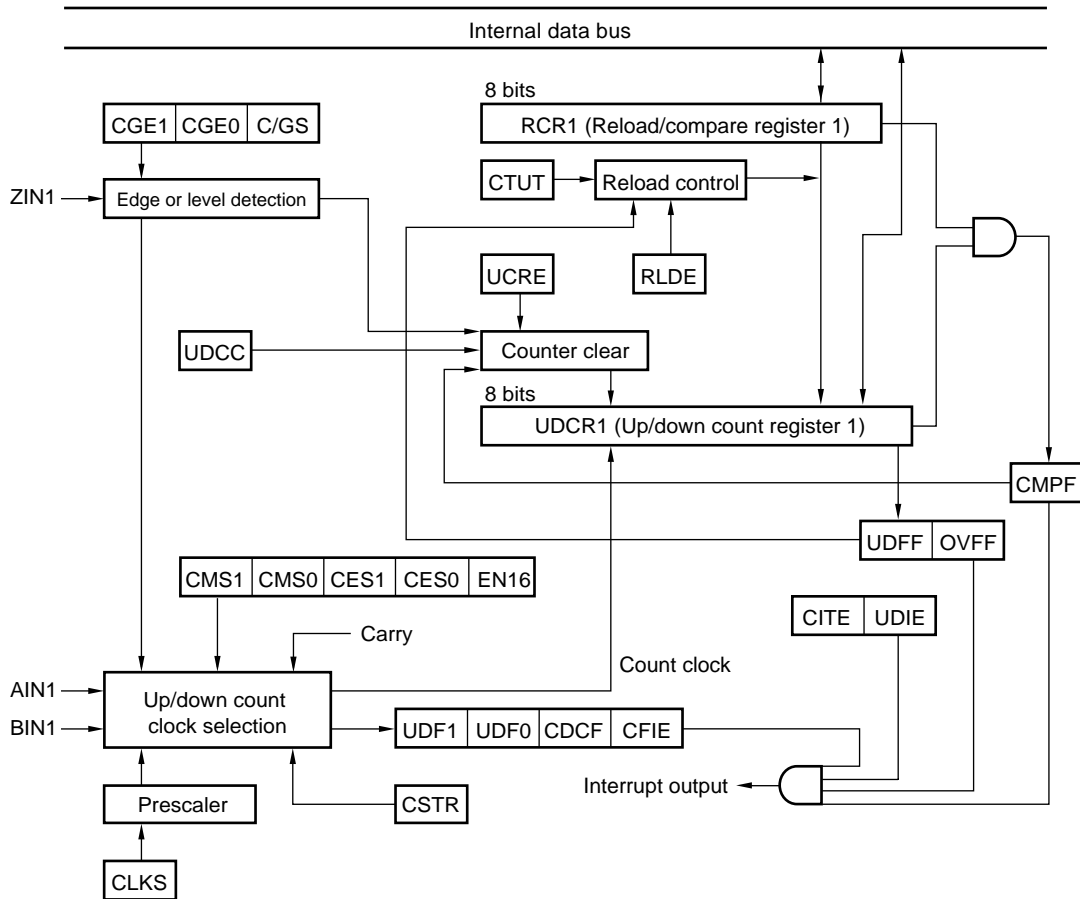

8. Clock Output Control Register

Clock output control register outputs the divided machine clock.

(1) Register Configuration

• Clock control register (CLKR)

	bit 7	bit 6	bit 5	bit 4	bit 3	bit 2	bit 1	bit 0	Initial value
Address : 00003EH	—	—	—	—	CKEN	FRQ2	FRQ1	FRQ0	----0000 _B
					R/W	R/W	R/W	R/W	

R/W : Readable and writable
— : Unused

bit 3: Clock output enable bit (CKEN)

MODE	Operation
0	Operate as a standard port.
1	Operate as the clock output.

bit 2 to bit 0: Clock output frequency select bit (FRQ2 to FRQ0)

These bits select the output frequency of the clock.

FRQ2	FRQ1	FRQ0	Output clock	$\phi = 16 \text{ MHz}$	$\phi = 8 \text{ MHz}$	$\phi = 4 \text{ MHz}$
0	0	0	$\phi/2^1$	125 ns	250 ns	500 ns
0	0	1	$\phi/2^2$	250 ns	500 ns	1 μs
0	1	0	$\phi/2^3$	500 ns	1 μs	2 μs
0	1	1	$\phi/2^4$	1 μs	2 μs	4 μs
1	0	0	$\phi/2^5$	2 μs	4 μs	8 μs
1	0	1	$\phi/2^6$	4 μs	8 μs	16 μs
1	1	0	$\phi/2^7$	8 μs	16 μs	32 μs
1	1	1	$\phi/2^8$	16 μs	32 μs	64 μs

MB90650A Series

9. DTP/External Interrupts

The DTP (Data Transfer Peripheral) is a peripheral block that interfaces external peripherals to the F²MC-16L CPU. The DTP receives DMA and interrupt processing requests from external peripherals and passes the requests to the F²MC-16L CPU to activate the intelligent I/O service or interrupt processing. Two request levels ("H" and "L") are provided for the intelligent I/O service. For external interrupt requests, generation of interrupts on a rising or falling edge as well as on "H" and "L" levels can be selected, giving a total of four types.

(1) Register Configuration

• Interrupt/DTP enable register (ENIR)									
	bit 7	bit 6	bit 5	bit 4	bit 3	bit 2	bit 1	bit 0	Initial value
Address : 000030 _H	EN7	EN6	EN5	EN4	EN3	EN2	EN1	EN0	00000000 _B
	R/W	R/W	R/W	R/W	R/W	R/W	R/W	R/W	
• Interrupt/DTP source register (EIRR)									
	bit 15	bit 14	bit 13	bit 12	bit 11	bit 10	bit 9	bit 8	Initial value
Address : 000031 _H	ER7	ER6	ER5	ER4	ER3	ER2	ER1	ER0	00000000 _B
	R/W	R/W	R/W	R/W	R/W	R/W	R/W	R/W	
• Request level setting register (ELVR)									
	bit 7	bit 6	bit 5	bit 4	bit 3	bit 2	bit 1	bit 0	Initial value
Address : 000032 _H	LB3	LA3	LB2	LA2	LB1	LA1	LB0	LA0	00000000 _B
	R/W	R/W	R/W	R/W	R/W	R/W	R/W	R/W	
	bit 15	bit 14	bit 13	bit 12	bit 11	bit 10	bit 9	bit 8	Initial value
Address : 000033 _H	LB7	LA7	LB6	LA6	LB5	LA5	LB4	LA4	00000000 _B
	R/W	R/W	R/W	R/W	R/W	R/W	R/W	R/W	
R/W : Readable and writable									

(2) Block Diagram

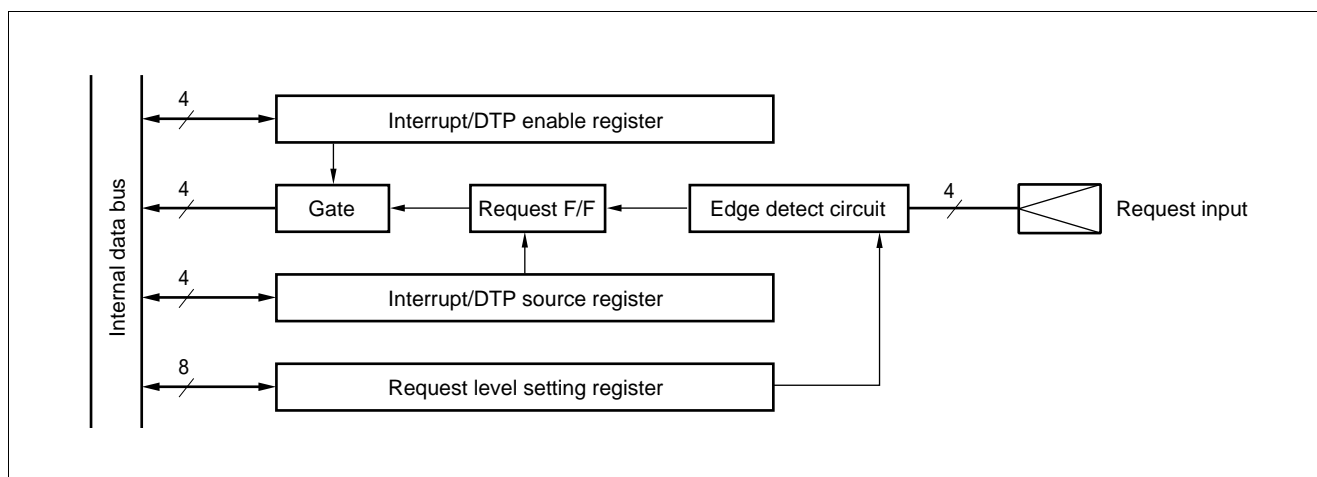

10. 16-bit I/O Timer

The 16-bit I/O timer consists of one 16-bit free-run timer, two output compare, and two input capture modules.

Based on the 16-bit free-run timer, these functions can be used to generate two independent waveform outputs and to measure input pulse widths and external clock periods.

• Register configuration

• 16-bit free-run timer

TCDTL : 000066_H
TCDTH : 000067_H

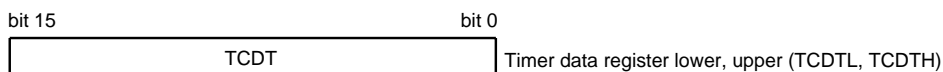

TCCS : 000068_H

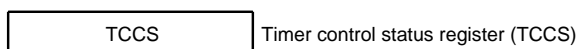

• 16-bit output compare

OCCP0 : 000050_H, 51_H
OCCP1 : 000052_H, 53_H
OCCP2 : 000054_H, 55_H
OCCP3 : 000056_H, 57_H

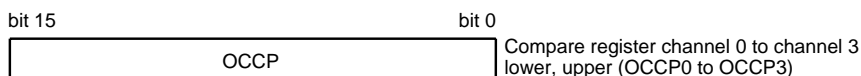

OCS0 : 000058_H
OCS1 : 000059_H
OCS2 : 00005A_H
OCS3 : 00005B_H

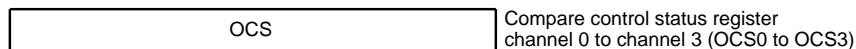

• 16-bit input capture

IPCP0 : 000060_H, 61_H
IPCP1 : 000062_H, 63_H

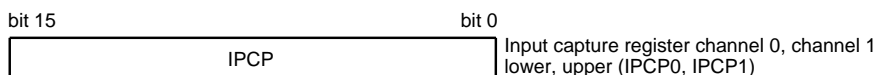

ICS0, 1 : 000064_H

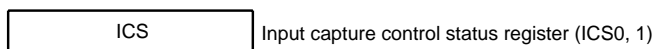

• Block diagram

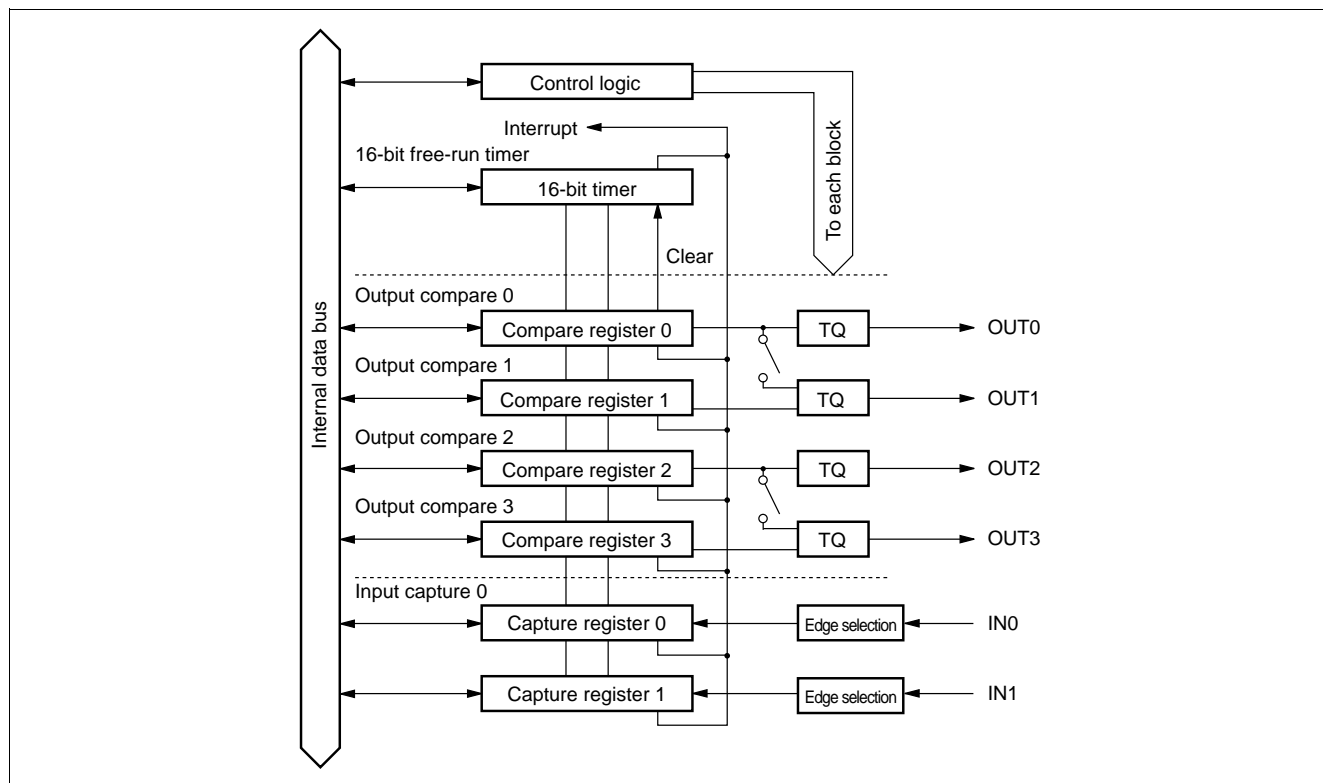

MB90650A Series

(1) 16-bit Free-run Timer

The 16-bit free-run timer consists of a 16-bit up-counter, a control register, and a prescaler. The output of the timer/counter is used as the base time for the input capture and output compare.

- The operating clock for the counter can be selected from four different clocks.
Four internal clocks ($\phi/4$, $\phi/16$, $\phi/32$, $\phi/64$)
- Interrupts can be generated when a counter value overflow or compare match with compare register 0 occurs (the appropriate mode must be set for a compare match).
- The counter can be initialized to 0000_H by a reset, software clear, or compare match with compare register 0.
- **Register details**

• Upper timer data register (TCDTH)

Address : 000067 _H	bit 15	bit 14	bit 13	bit 12	bit 11	bit 10	bit 9	bit 8	Initial value
	T15	T14	T13	T12	T11	T10	T09	T08	0000000 _B
	R/W	R/W	R/W	R/W	R/W	R/W	R/W	R/W	

• Lower timer data register (TCDTL)

Address : 000066 _H	bit 7	bit 6	bit 5	bit 4	bit 3	bit 2	bit 1	bit 0	Initial value
	T07	T06	T05	T04	T03	T02	T01	T00	0000000 _B
	R/W	R/W	R/W	R/W	R/W	R/W	R/W	R/W	

R/W : Readable and writable

The count value of the 16-bit free-run timer can be read from this register. The count is cleared to "0000_B" by a reset. Writing to this register sets the timer value. However, only write to the register when the timer is halted (STOP = "1"). Always use word access.

The 16-bit free-run timer is initialized by the following.

- Reset
- The clear bit (CLR) of the control status register
- A match between the timer/counter value and compare register 0 of the output compare (if the appropriate mode is set)
- **Block diagram**

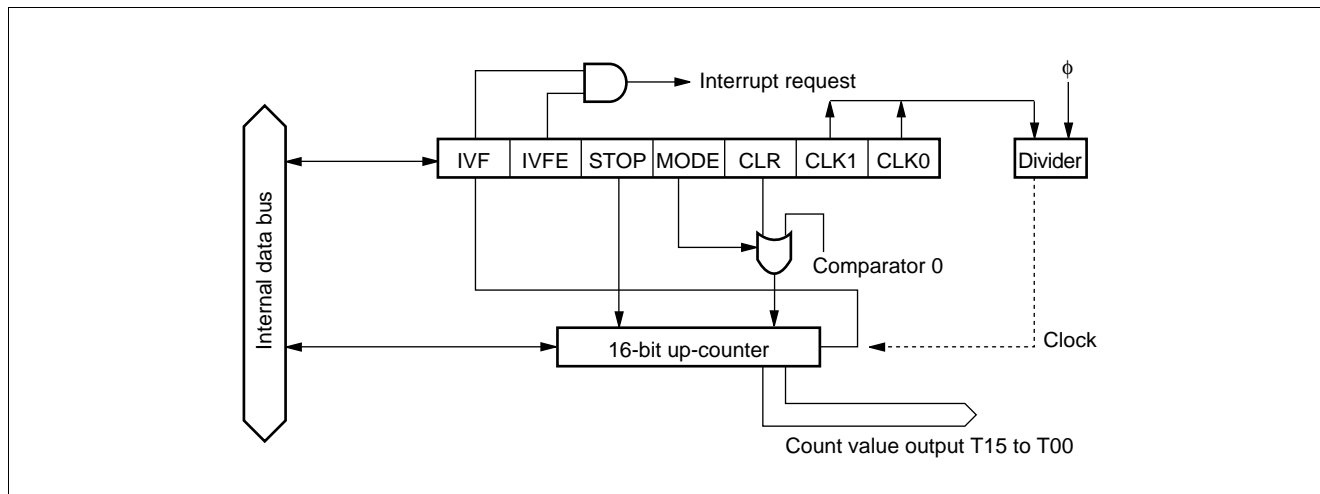

(2) Output Compare

The output compare consists of two 16-bit compare registers, compare output latches, and control registers. The modules can invert the output level and generate an interrupt when the 16-bit free-run timer value matches the compare register value.

- The four compare registers can be operated independently.
Each compare register has a corresponding output pin and interrupt flag.
- The four compare registers can be paired to control the output pins.
Invert the output pins using the four compare registers.
- Initial values can be set for the output pins.
- An interrupt can be generated when a compare match occurs.

• Register configuration

• Upper compare register channel 0 to channel 3 (OCCP0 to OCCP3)

OCCP0 : 000051H	bit 15	bit 14	bit 13	bit 12	bit 11	bit 10	bit 9	bit 8	Initial value
OCCP1 : 000053H	C15	C14	C13	C12	C11	C10	C09	C08	XXXXXXXX _B
OCCP2 : 000055H	R/W	R/W	R/W	R/W	R/W	R/W	R/W	R/W	
OCCP3 : 000057H									

• Lower compare register channel 0 to channel 3 (OCCP0 to OCCP3)

OCCP0 : 000050H	bit 7	bit 6	bit 5	bit 4	bit 3	bit 2	bit 1	bit 0	Initial value
OCCP1 : 000052H	C07	C06	C05	C04	C03	C02	C01	C00	XXXXXXXX _B
OCCP2 : 000054H	R/W	R/W	R/W	R/W	R/W	R/W	R/W	R/W	
OCCP3 : 000056H									

• Compare control status register channel 0 to channel 3 (OCS0 to OCS3)

OCS1 : 000059H	bit 15	bit 14	bit 13	bit 12	bit 11	bit 10	bit 9	bit 8	Initial value
OCS3 : 00005BH	—	—	—	CMOD	OTE1	OTEO	OTDI	OTD0	---0000 _B
	—	—	—	R/W	R/W	R/W	R/W	R/W	
	bit 7	bit 6	bit 5	bit 4	bit 3	bit 2	bit 1	bit 0	Initial value
OCS0 : 000058H	ICP1	ICP0	ICE1	ICE0	—	—	CST1	CST0	0000--00 _B
OCS2 : 00005AH	R/W	R/W	R/W	R/W	—	—	R/W	R/W	

R/W: Readable and writable

— : Unused

X : Indeterminate

MB90650A Series

• Block diagram

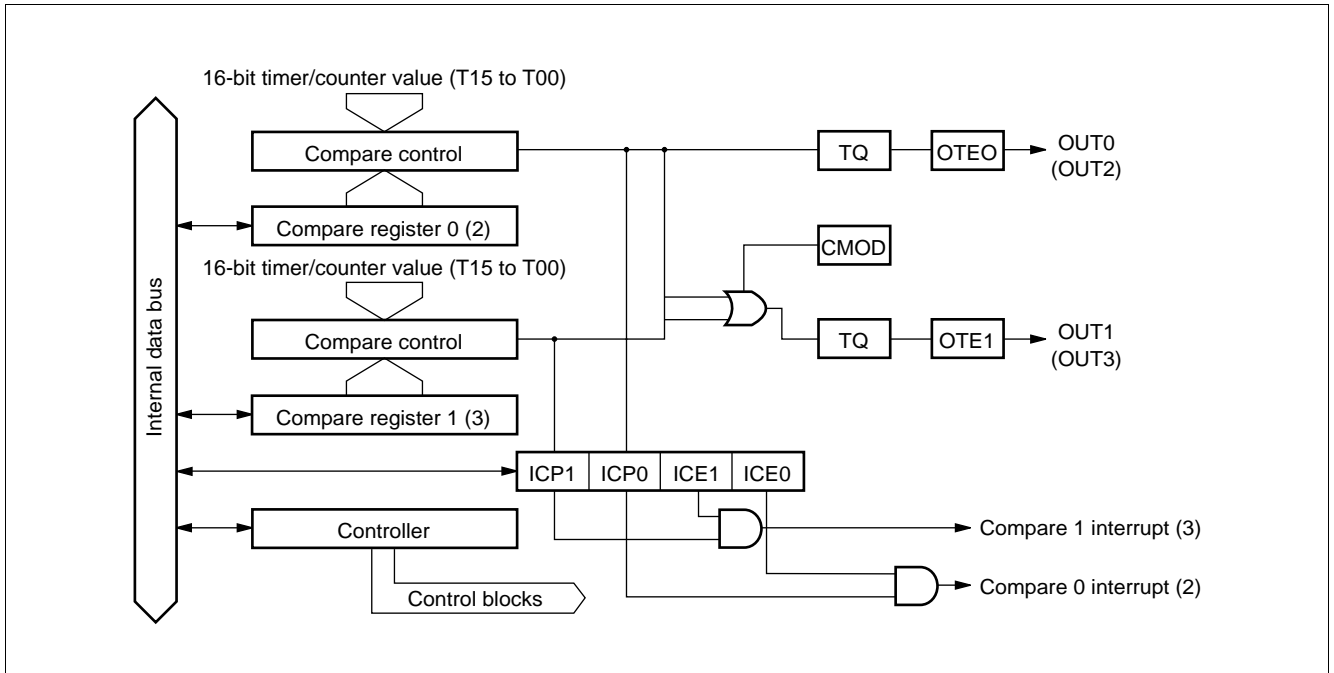

(3) Input Capture

The input capture consists of two independent external input pins, their corresponding capture registers, and a control register. The value of the 16-bit free-run timer can be stored in the capture register and an interrupt generated when the specified edge is detected on the signal from the external input pin.

- The edge to detect on the external input signal is selectable.
Detection of rising edges, falling edges, or either edge can be specified.
- The two input capture channels can operate independently.
- An interrupt can be generated on detection of the specified edge on the external input signal.

The input capture interrupt can activate the intelligent I/O service.

• Register details

• Input capture register channel 0, channel 1 (ICP0, ICP1)

ICP0 : 000061H ICP1 : 000063H	bit 15	bit 14	bit 13	bit 12	bit 11	bit 10	bit 9	bit 8	Initial value
	CP15	CP14	CP13	CP12	CP11	CP10	CP09	CP08	XXXXXXXXB
	R	R	R	R	R	R	R	R	
ICP0 : 000060H ICP1 : 000062H	bit 7	bit 6	bit 5	bit 4	bit 3	bit 2	bit 1	bit 0	Initial value
	CP07	CP06	CP05	CP04	CP03	CP02	CP01	CP00	XXXXXXXXB
	R	R	R	R	R	R	R	R	

• Input capture control status register (ICS0, 1)

000064H	bit 7	bit 6	bit 5	bit 4	bit 3	bit 2	bit 1	bit 0	Initial value
	ICP1	ICP0	ICE1	ICE0	EG11	EG10	EG01	EG00	00000000B
	R/W	R/W	R/W	R/W	R/W	R/W	R/W	R/W	

R/W : Readable and writable
R : Read only
X : Indeterminate

The 16-bit free-run timer value is stored in these registers when the specified edge is detected on the input waveform from the corresponding external pin. (Always use word access. Writing is prohibited.)

• Block diagram

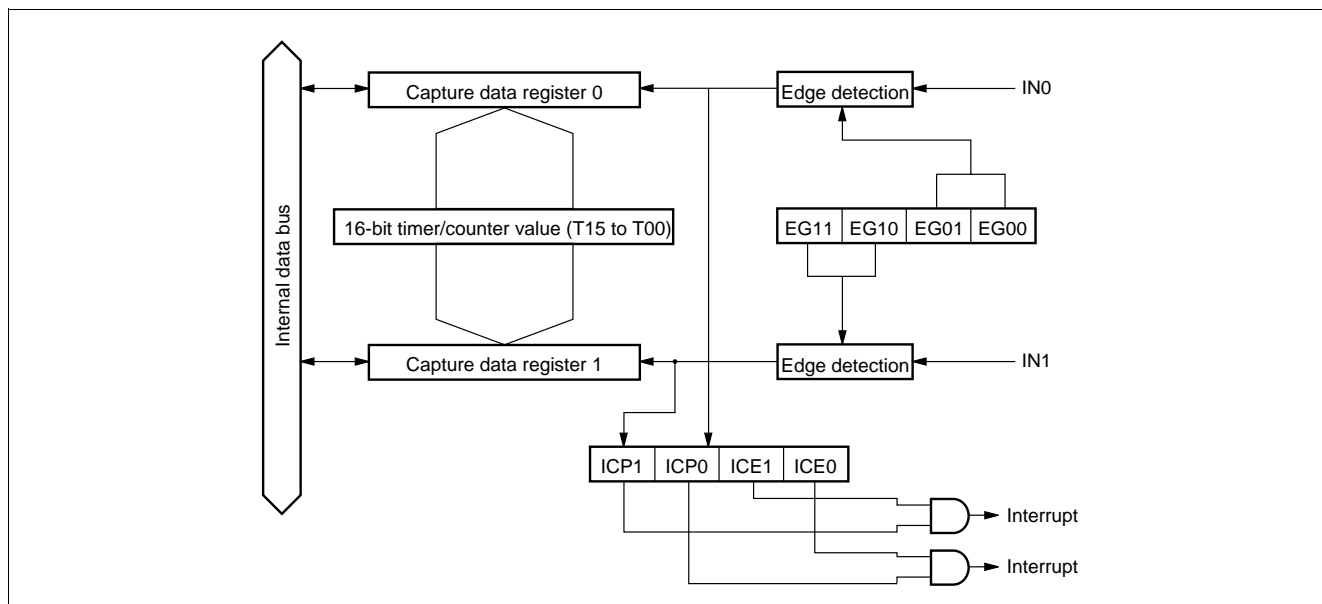

MB90650A Series

11. Watchdog Timer, Timebase Timer, and Watch Timer

The watchdog timer consists of a 2-bit watchdog counter that uses the carry signal from the 18-bit timebase timer or the 15-bit watch timer as a clock source, a control register, and a watchdog reset controller.

The timebase timer consists of an 18-bit timer and a circuit that controls interval interrupts. Note that the timebase timer uses the main clock, regardless of the setting of the MCS bit and SCS bit in CKSCR.

The watch timer consists of a 15-bit timer and a circuit that controls interval interrupts. Note that the watch timer uses the sub clock, regardless of the setting of the MCS bit SCS bit in CKSCR.

(1) Register Configuration

• Watchdog timer control register (WDTC)

	bit 7	bit 6	bit 5	bit 4	bit 3	bit 2	bit 1	bit 0	Initial value
Address : 0000A8H	PONR	—	WRST	ERST	SRST	WTE	WT1	WT0	XXXXX111 _B
	R	—	R	R	R	W	W	W	

• Timebase timer control register (TBTC)

	bit 15	bit 14	bit 13	bit 12	bit 11	bit 10	bit 9	bit 8	Initial value
Address : 0000A9H	Reserved	—	—	TBIE	TBOF	TBR	TBC1	TBC0	1--00000 _B
	—	—	—	R/W	R/W	W	R/W	R/W	

• Watch timer control register (WTC)

	bit 7	bit 6	bit 5	bit 4	bit 3	bit 2	bit 1	bit 0	Initial value
Address : 0000AAH	WDCS	SCE	WTIE	WTOF	WTR	WTC2	WTC1	WTC0	1X000000 _B
	R/W	R	R/W	R/W	R	R/W	R/W	R/W	

R/W : Readable and writable
 R : Read only
 W : Write only
 — : Unused
 X : Indeterminate

MB90650A Series

(2) Block Diagram

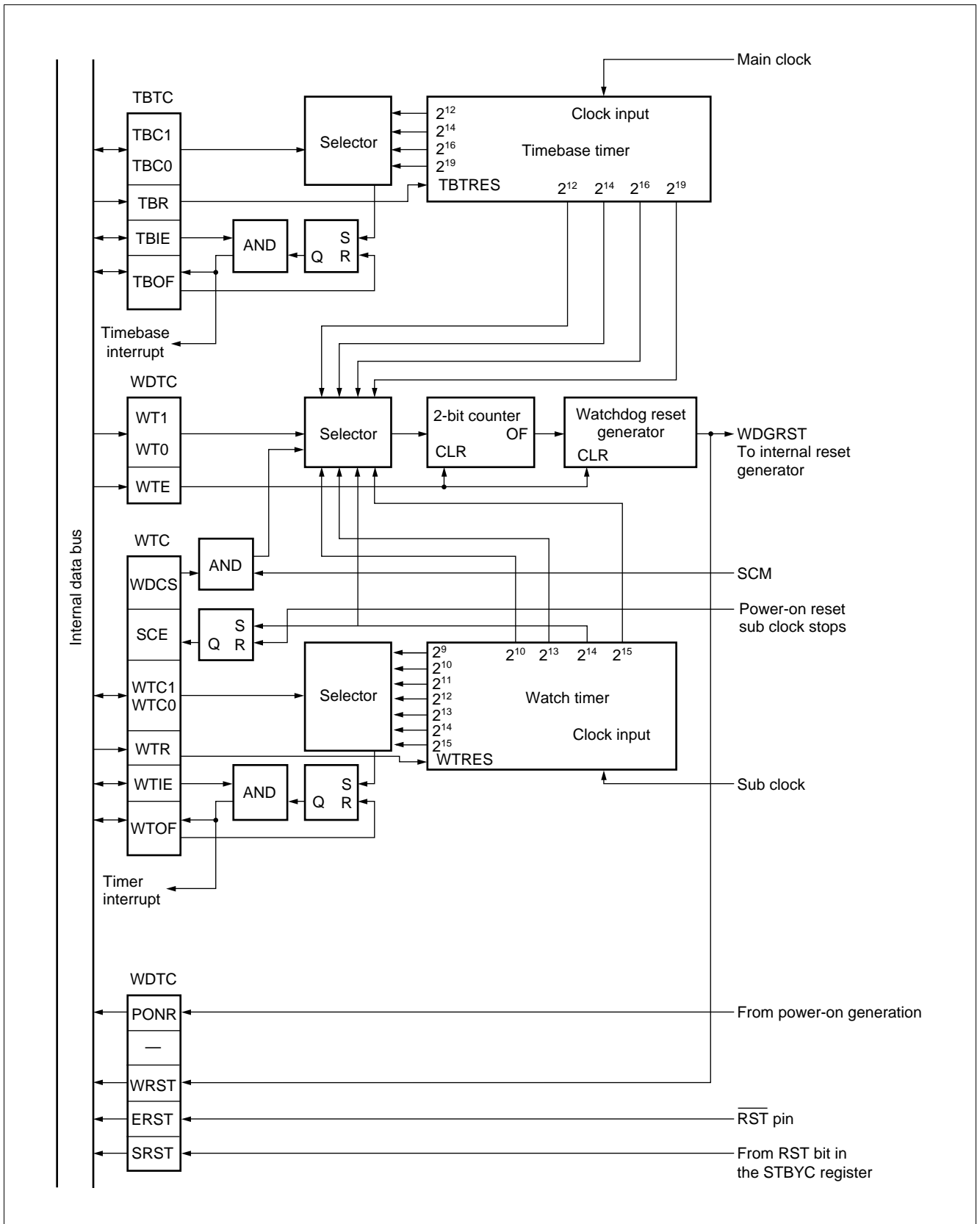

MB90650A Series

12. I²C Interface

The I²C interface is a serial I/O port that supports the Inter-IC bus and operates as a master/slave device on the I²C bus. This module has the following features:

- Master/slave transmission/reception
- Arbitration function
- Clock synchronization function
- Slave address/general call address detection function
- Transfer direction detection function
- Start condition repeat generation and detection function
- Bus error detection function

(1) Register Configuration

• I²C bus status register (IBSR)

Address : 000080 _H	bit 7	bit 6	bit 5	bit 4	bit 3	bit 2	bit 1	bit 0	Initial value
	BB	RSC	AL	LRB	TRX	AAS	GCA	FBT	00000000 _B
	R	R	R	R	R	R	R	R	

• I²C bus control register (IBCR)

Address : 000081 _H	bit 15	bit 14	bit 13	bit 12	bit 11	bit 10	bit 9	bit 8	Initial value
	BER	BEIE	SCC	MSS	ACK	GCAA	INTE	INT	00000000 _B
	R/W	R/W	R/W	R/W	R/W	R/W	R/W	R/W	

• I²C bus clock control register (ICCR)

Address : 000082 _H	bit 7	bit 6	bit 5	bit 4	bit 3	bit 2	bit 1	bit 0	Initial value
	—	—	EN	CS4	CS3	CS2	CS1	CS0	--0XXXXX _B
	—	—	R/W	R/W	R/W	R/W	R/W	R/W	

• I²C bus address register (IADR)

Address : 000083 _H	bit 15	bit 14	bit 13	bit 12	bit 11	bit 10	bit 9	bit 8	Initial value
	—	A6	A5	A4	A3	A2	A1	A0	-XXXXXXXX _B
	—	R/W	R/W	R/W	R/W	R/W	R/W	R/W	

• I²C bus data register (IDAR)

Address : 000084 _H	bit 7	bit 6	bit 5	bit 4	bit 3	bit 2	bit 1	bit 0	Initial value
	D7	D6	D5	D4	D3	D2	D1	D0	XXXXXXXX _B
	R/W	R/W	R/W	R/W	R/W	R/W	R/W	R/W	

R/W : Readable and writable
 R : Read only
 — : Unused
 X : Indeterminate

(2) Block Diagram

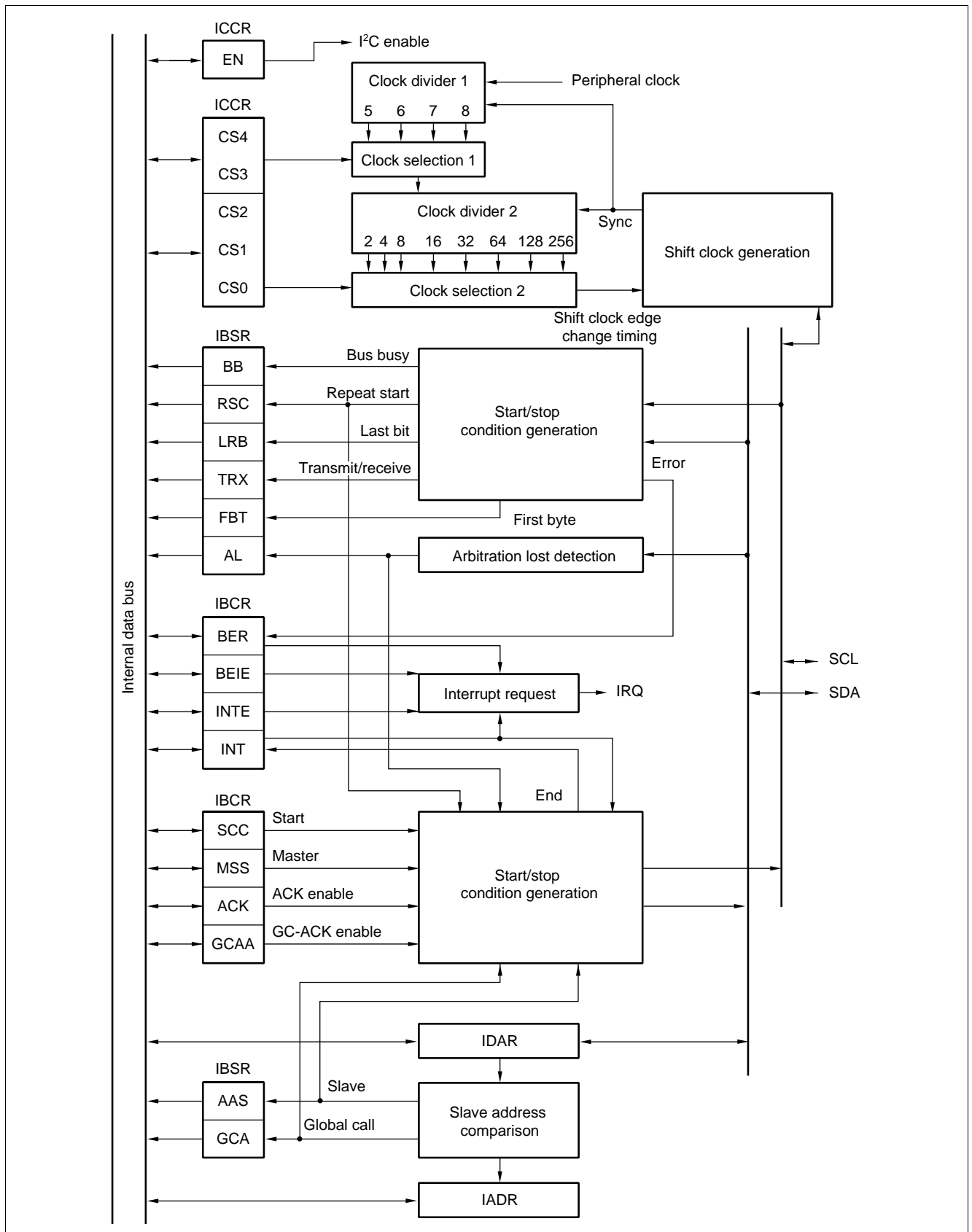

MB90650A Series

13. External Bus Pin Control Circuit

The external bus pin control circuit controls the external bus pins required to extend the CPU's address/data bus outside the device.

(1) Register Configuration

• Auto-ready function selection register (ARSR)

Address : 0000A5 _H	bit 15	bit 14	bit 13	bit 12	bit 11	bit 10	bit 9	bit 8	Initial value
	ICR1	ICR0	HMR1	HMR0	—	—	LMR1	LMR0	0011--00 _B
	W	W	W	W	—	—	W	W	

• External address output control register (HACR)

Address : 0000A6 _H	bit 7	bit 6	bit 5	bit 4	bit 3	bit 2	bit 1	bit 0	Initial value
	E23	E22	E21	E20	E19	E18	E17	E16	00000000 _B
	W	W	W	W	W	W	W	W	

• Bus control signal selection register (ECSR)

Address : 0000A7 _H	bit 15	bit 14	bit 13	bit 12	bit 11	bit 10	bit 9	bit 8	Initial value
	CKE	RYE	HDE	ICBS	HMBS	WRE	LMBS	—	0000*00- _B
	W	W	W	W	W	W	W	—	

W : Write only
 — : Unused
 * : "1" or "0"

(2) Block Diagram

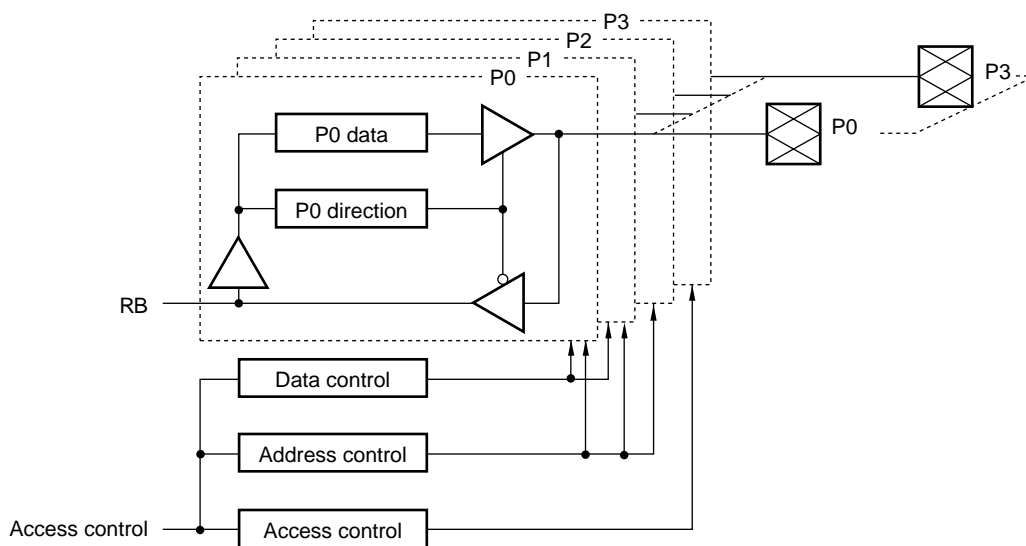

14. Low-power Consumption Mode (CPU Intermittent Operation Function, Oscillation Stabilization Delay Time, Clock Multiplier Function)

The following are the operating modes: PLL clock mode, PLL sleep mode, PLL watch mode, pseudo-watch mode, main clock mode, main sleep mode, main watch mode, main stop mode, sub clock mode, sub sleep mode, sub watch mode, and sub stop mode. Aside from the PLL clock mode, all of the other operating modes are low-power consumption modes.

In main clock mode and main sleep mode, the main clock (main OSC oscillation clock) and the sub clock (sub OSC oscillation clock) operate. In these modes, the main clock divided by 2 is used as the operation clock, the sub clock (sub OSC oscillation clock) is used as the timer clock, and the PLL clock (VCO oscillation clock) is stopped.

In sub clock mode and sub sleep mode, only the sub clock operates. In these modes, the sub clock is used as the operation clock, and the main clock and PLL clock are stopped.

In PLL sleep mode and main sleep mode, only the CPU's operation clock is stopped; all clocks other than the CPU clock operate.

In pseudo-watch mode, only the watch timer and timebase timer operate.

In PLL watch mode, main watch mode, and sub watch mode, only the watch timer operates. In this mode, only the sub clock is used for operation, while the main clock and the PLL clock are stopped (the difference between the PLL watch mode, the main watch mode and the sub watch mode is that it resumes operation after an interrupt in the PLL clock mode, the main clock mode, and the sub clock mode respectively, and there is no reference concerning about clock mode operation).

The main stop mode, sub stop mode, and hardware standby mode stop oscillation, making it possible to retain data while consuming the least amount of power. (The difference between the main stop mode and the sub stop mode is that it resumes operation in the main clock mode and the sub clock mode respectively, and there is no reference concerning about stop mode operation).

The CPU intermittent operation function intermittently runs the clock supplied to the CPU when accessing registers, on-chip memory, on-chip resources, and the external bus. Processing is possible with lower power consumption by reducing the execution speed of the CPU while supplying a high-speed clock and using on-chip resources.

The PLL clock multiplier can be selected as either 2, 4, 6, or 8 by setting the CS1 and CS0 bits. These clocks are divided by 2 to be used as a machine clock.

The WS1 and WS0 bits can be used to set the main clock oscillation stabilization delay time for when stop mode is woken up.

MB90650A Series

(1) Register Configuration

• Low-power consumption mode control register (LPMCR)

Address : 0000A0H	bit 7	bit 6	bit 5	bit 4	bit 3	bit 2	bit 1	bit 0	Initial value
	STP	SLP	SPL	RST	TMD	CG1	CG0	—	00011000 _B
	W	W	R/W	W	W	R/W	R/W		

• Clock selection register (CKSCR)

Address : 0000A1H	bit 15	bit 14	bit 13	bit 12	bit 11	bit 10	bit 9	bit 8	Initial value
	SCM	MCM	WS1	WS0	SCS	MCS	CS1	CS0	11111100 _B
	R	R	R/W	R/W	R/W	R/W	R/W	R/W	

R/W : Readable and writable
 R : Read only
 W : Write only
 — : Unused

(2) Block Diagram

• Low-power consumption control circuit and clock generator

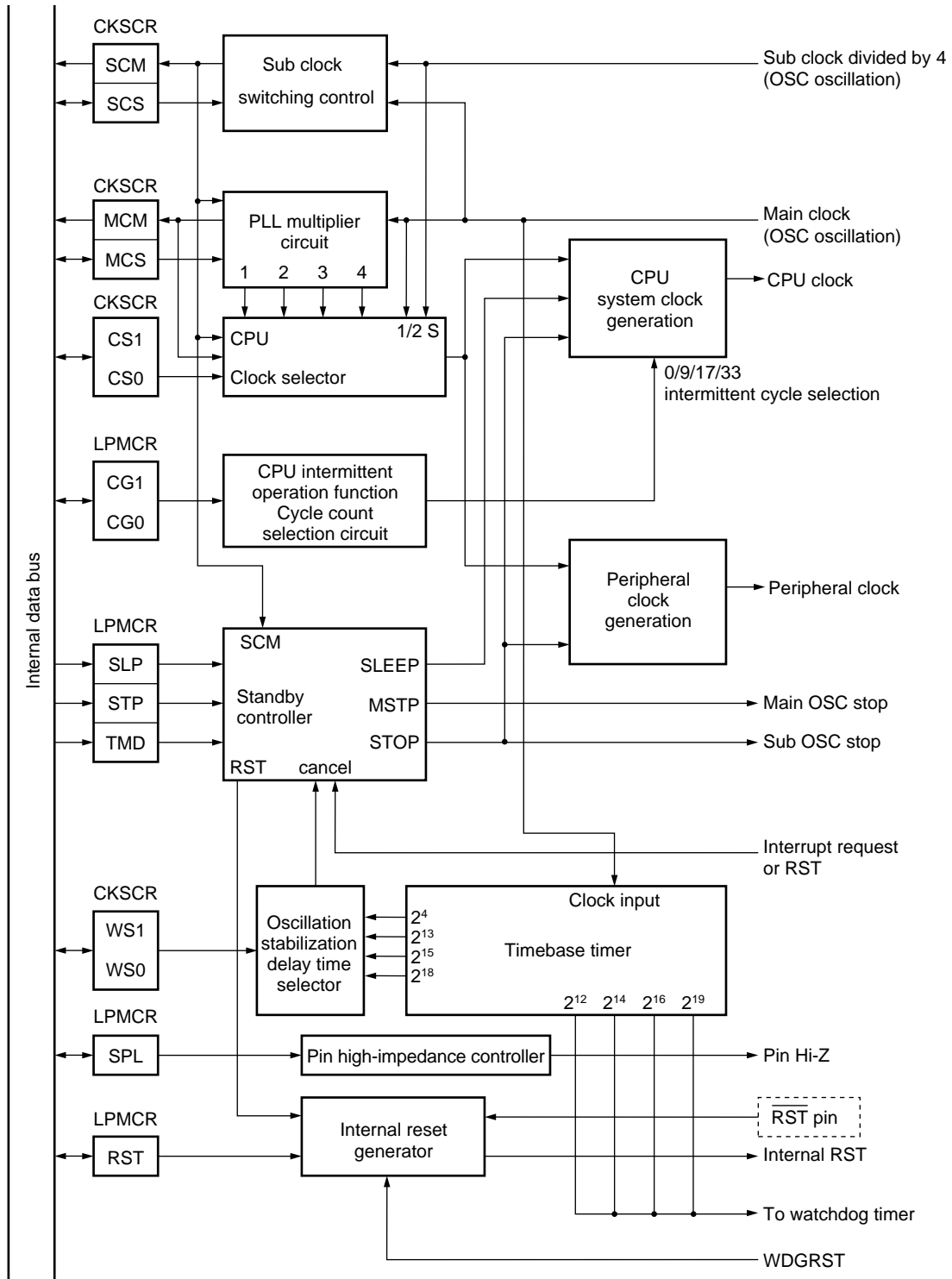

MB90650A Series

• State transition diagram for clock selection (1)

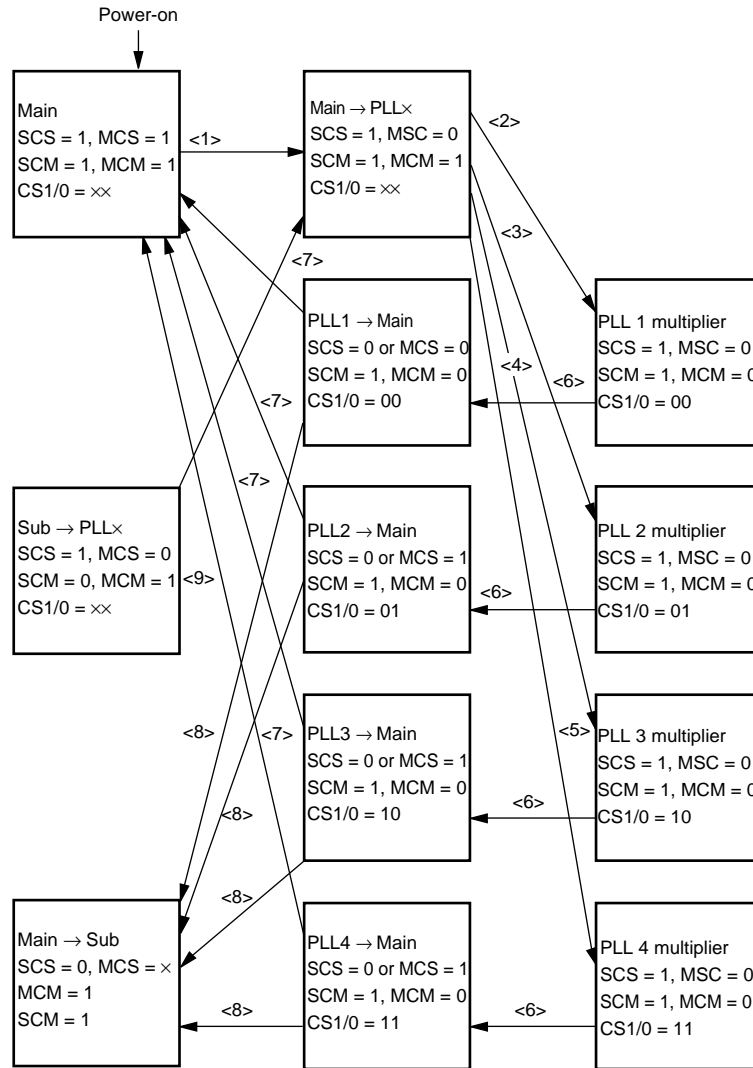

- <1> MCS bit cleared and SCS bit set
- <2> PLL clock oscillation stabilization delay complete and CS1/0 = 00
- <3> PLL clock oscillation stabilization delay complete and CS1/0 = 01
- <4> PLL clock oscillation stabilization delay complete and CS1/0 = 10
- <5> PLL clock oscillation stabilization delay complete and CS1/0 = 11
- <6> MCS bit set or SCS bit cleared
- <7> PLL clock and main clock synchronized timing and SCS = 1
- <8> PLL clock and main clock synchronized timing and SCS = 0
- <9> Main clock oscillation stabilization delay complete and MCS = 0

• State transition diagram for clock selection (2)

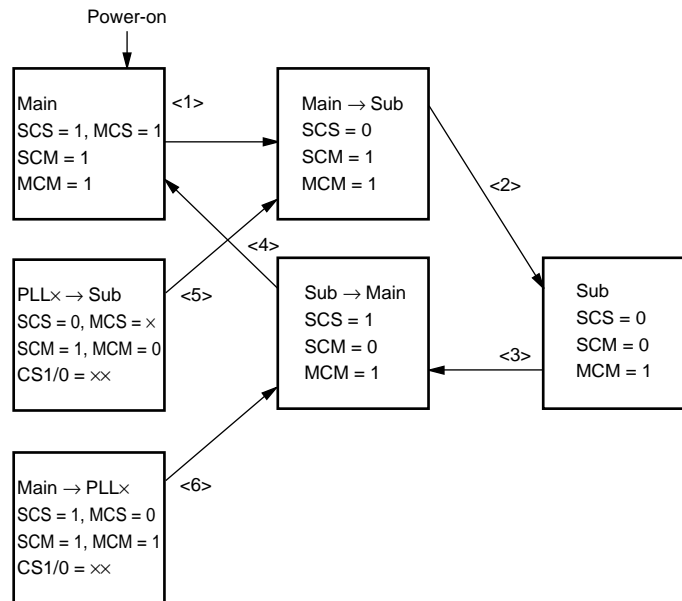

<1> SCS bit cleared

<2> Sub clock edge detection timing

<3> SCS bit set

<4> Main clock oscillation stabilization delay complete and MCS = 1

<5> PLL clock and main clock synchronized timing and SCS = 0

<6> Main clock oscillation stabilization delay complete and MCS = 0

MB90650A Series

15. Delayed Interrupt Generation Module

The delayed interrupt generation module is used to generate the task switching interrupt. Interrupt requests to the F²MC-16L CPU can be generated and cleared by software using this module.

(1) Register Details

• Delayed interrupt generation /release register (DIRR)								Initial value	
Address	bit 15	bit 14	bit 13	bit 12	bit 11	bit 10	bit 9	bit 8	
00009F _H	—	—	—	—	—	—	—	R0	-----0 _B
								R/W	

R/W : Readable and writable
 — : Unused

The DIRR register controls generation and clearing of delayed interrupt requests. Writing “1” to the register generates a delayed interrupt request. Writing “0” to the register clears the delayed interrupt request. The register is set to the interrupt cleared state by a reset. Either “0” or “1” can be written to the reserved bits. However, considering possible future extensions, it is recommended that the set bit and clear bit instructions are used for register access.

(2) Block Diagram

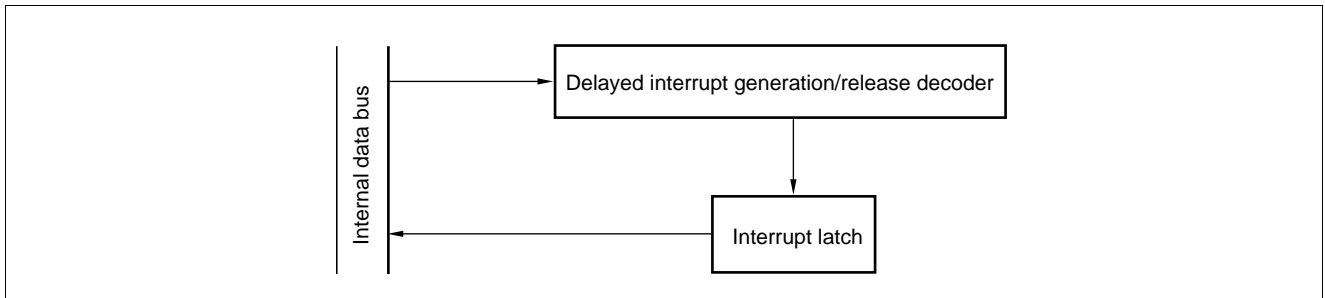

MB90650A Series

■ ELECTRICAL CHARACTERISTICS

1. Absolute Maximum Ratings

($V_{SS} = AV_{SS} = 0.0\text{ V}$)

Parameter	Symbol	Value		Unit	Remarks
		Min.	Max.		
Power supply voltage	V_{CC}	$V_{SS} - 0.3$	$V_{SS} + 4.0$	V	MB90652A/653A
		$V_{SS} - 0.3$	$V_{SS} + 7.0$	V	MB90P653A
	AV_{CC}	$V_{SS} - 0.3$	$V_{SS} + 4.0$	V	MB90652A/653A *1
		$V_{SS} - 0.3$	$V_{SS} + 7.0$	V	MB90P653A *1
	AVRH AVRL	$V_{SS} - 0.3$	$V_{SS} + 4.0$	V	MB90652A/653A
		$V_{SS} - 0.3$	$V_{SS} + 7.0$	V	MB90P653A
	DVRH	$V_{SS} - 0.3$	$V_{SS} + 4.0$	V	MB90652A/653A
		$V_{SS} - 0.3$	$V_{SS} + 7.0$	V	MB90P653A
Input voltage	V_i	$V_{SS} - 0.3$	$V_{SS} + 4.0$	V	MB90652A/653A *2
		$V_{SS} - 0.3$	$V_{SS} + 7.0$	V	MB90P653A *2
Output voltage	V_o	$V_{SS} - 0.3$	$V_{SS} + 4.0$	V	MB90652A/653A *2
		$V_{SS} - 0.3$	$V_{SS} + 7.0$	V	MB90P653A *2
“L” level maximum output current	I_{OL}	—	10	mA	MB90652A/653A *3
		—	15	mA	MB90P653A *3
“L” level average output current	I_{OLAV}	—	3	mA	MB90652A/653A *4
		—	4	mA	MB90P653A *4
“L” level total maximum output current	ΣI_{OL}	—	60	mA	MB90652A/653A
		—	100	mA	MB90P653A
“L” level total average output current	ΣI_{OLAV}	—	30	mA	MB90652A/653A *5
		—	50	mA	MB90P653A *5
“H” level maximum output current	I_{OH}	—	-10	mA	MB90652A/653A *3
		—	-15	mA	MB90P653A *3
“H” level average output current	I_{OHAV}	—	-3	mA	MB90652A/653A *4
		—	-4	mA	MB90P653A *4
“H” level total maximum output current	ΣI_{OH}	—	-60	mA	MB90652A/653A
		—	-100	mA	MB90P653A
“H” level total average output current	ΣI_{OHAV}	—	-30	mA	MB90652A/653A *5
		—	-30	mA	MB90P653A *5
Power consumption	P_D	—	200	mW	

(Continued)

MB90650A Series

(Continued)

 $(V_{SS} = AV_{SS} = 0.0 \text{ V})$

Parameter	Symbol	Value		Unit	Remarks
		Min.	Max.		
Operating temperature	T_A	-40	+85	°C	
Storage temperature	T_{stg}	-55	+150	°C	

*1: AV_{CC} , AV_{RH} , and AV_{RL} must not exceed V_{CC} . Similarly, it must not exceed AV_{RH} and AV_{RL} .

*2: V_I and V_O must not exceed $V_{CC} + 0.3 \text{ V}$.

*3: Maximum output current specifies the peak value or one corresponding pin.

*4: The average output current is the rating for the current from an individual pin averaged over 100 ms.

*5: The average total output current is the rating for the current from all pins averaged over 100 ms.

WARNING: Semiconductor devices can be permanently damaged by application of stress (voltage, current, temperature, etc.) in excess of absolute maximum ratings. Do not exceed these ratings.

2. Recommended Operating Conditions

 $(V_{SS} = AV_{SS} = 0.0 \text{ V})$

Parameter	Symbol	Value		Unit	Remarks
		Min.	Max.		
Power supply voltage	V_{CC}	2.2	3.6	V	For normal operation (MB90652A/653A) *
		2.7	3.6	V	For normal operation (MB90P653A)
	V_{CC}	2.2	3.6	V	To maintain statuses in stop mode (MB90652A/653A)
		2.0	5.5	V	To maintain statuses in stop mode (MB90P653A)
"H" level input voltage	V_{IH}	$0.7 V_{CC}$	$V_{CC} + 0.3$	V	Pins other than V_{IHS} and V_{IHM}
	V_{IHS}	$0.8 V_{CC}$	$V_{CC} + 0.3$	V	Hysteresis input pins
	V_{IHM}	$V_{CC} - 0.3$	$V_{CC} + 0.3$	V	MD pin input
	V_{IHT}	2.4	$V_{CC} + 0.3$	V	TTL input pins
"L" level input voltage	V_{IL}	$V_{SS} - 0.3$	$0.3 V_{CC}$	V	Pins other than V_{ILS} and V_{ILM}
	V_{ILS}	$V_{SS} - 0.3$	$0.2 V_{CC}$	V	Hysteresis input pins
	V_{ILM}	$V_{SS} - 0.3$	$V_{SS} + 0.3$	V	MD pin input
	V_{ILT}	$V_{SS} - 0.3$	0.8	V	TTL input pins
Operating temperature	T_A	-40	+85	°C	

* : I²C must be used at above 2.7 V.

WARNING: Recommended operating conditions are normal operating ranges for the semiconductor device. All the device's electrical characteristics are warranted when operated within these ranges.

Always use semiconductor devices within the recommended operating conditions. Operation outside these ranges may adversely affect reliability and could result in device failure.

No warranty is made with respect to uses, operating conditions, or combinations not represented on the data sheet. Users considering application outside the listed conditions are advised to contact their FUJITSU representative beforehand.

MB90650A Series

3. DC Characteristics

(MB90652A/653A: $V_{CC} = 2.2\text{ V}$ to 3.6 V , $V_{SS} = 0.0\text{ V}$, $T_A = -40^\circ\text{C}$ to $+85^\circ\text{C}$)(MB90P653A: $V_{CC} = 2.7\text{ V}$ to 3.3 V , $V_{SS} = 0.0\text{ V}$, $T_A = -40^\circ\text{C}$ to $+85^\circ\text{C}$)

Parameter	Symbol	Pin name	Condition	Value			Unit	Remarks
				Min.	Typ.	Max.		
"H" level output voltage	V_{OH}	Pins except P47, P70 to P72	$V_{CC} = 2.7\text{ V}$, $I_{OH} = -1.6\text{ mA}$	$V_{CC} - 0.3$	—	—	V	*
"L" level output voltage	V_{OL}	All output pins	$V_{CC} = 2.7\text{ V}$, $I_{OL} = 2.0\text{ mA}$	—	—	0.4	V	
Input leakage current	I_{IL}	Except P50 to P57, P90, P91	$V_{CC} = 3.3\text{ V}$, $V_{SS} < V_I < V_{CC}$	-10	—	10	μA	
Pull-up resistor	RPULL	—	When $V_{CC} = 3.0\text{ V}$, $T_A = +25^\circ\text{C}$	40	80	400	$\text{k}\Omega$	MB90P653A
				20	65	200	$\text{k}\Omega$	MB90652A/653A
Open-drain output leakage current	I_{leak}	P40 to P47, P70 to P72	—	—	0.1	10	μA	
Power supply current	I_{CC}	—	When $V_{CC} = 3.0\text{ V}$ Internal 8 MHz operation	—	10	20	mA	MB90652A/653A: During normal operation
	I_{CC}			—	17	24	mA	MB90652A/653A: In A/D operation
	I_{CC}			—	19	26	mA	MB90652A/653A: In D/A operation
	I_{CCS}			—	2.5	5	mA	MB90652A/653A: During sleep
	I_{CC}	—	When $V_{CC} = 3.0\text{ V}$ Internal 8 MHz operation	—	20	27	mA	MB90P653A: During normal operation
	I_{CC}			—	24	31	mA	MB90P653A: In A/D operation
	I_{CC}			—	26	33	mA	MB90P653A: In D/A operation
	I_{CCS}			—	4.2	10	mA	MB90P653A: During sleep
	I_{CC}	—	When $V_{CC} = 3.0\text{ V}$ Internal 16 MHz operation	—	20	35	mA	MB90652A/653A: During normal operation
	I_{CC}			—	31	41	mA	MB90652A/653A: In A/D operation
	I_{CC}			—	34	42	mA	MB90652A/653A: In D/A operation
	I_{CCS}			—	4.8	10	mA	MB90652A/653A: During sleep
	I_{CCH}			—	$T_A = +25^\circ\text{C}$	—	0.1	20

(Continued)

MB90650A Series

(Continued)

(MB90652A/653A: $V_{CC} = 2.2\text{ V to }3.6\text{ V}$, $V_{SS} = 0.0\text{ V}$, $T_A = -40^\circ\text{C to }+85^\circ\text{C}$)

(MB90P653A: $V_{CC} = 2.7\text{ V to }3.3\text{ V}$, $V_{SS} = 0.0\text{ V}$, $T_A = -40^\circ\text{C to }+85^\circ\text{C}$)

Parameter	Symbol	Pin name	Condition	Value			Unit	Remarks
				Min.	Typ.	Max.		
Power supply current	I_{CCL}	—	$V_{CC} = 3.0\text{ V}$, $T_A = +25^\circ\text{C}$ External 32 kHz operation	—	16	140	μA	MB90652A/653A: In sub operation
	I_{CCL}			—	4.4	6	mA	MB90P653A: In sub operation
	I_{CCT}	—	$V_{CC} = 3.0\text{ V}$, $T_A = +25^\circ\text{C}$ External 32 kHz operation	—	10	30	μA	MB90652A/653A: In watch mode
	I_{CCT}			—	15	60	μA	MB90P653A: In watch mode
Input capacitance	C_{IN}	Except AV_{CC} , AV_{SS} , V_{CC} , V_{SS}	—	—	10	80	pF	

* : P40 to P46 are N-ch open-drain pins to be controlled and are usually used as CMOS devices.

MB90650A Series

4. AC Characteristics

(1) Clock Timing

($V_{CC} = 2.7\text{ V to }3.3\text{ V}$, $V_{SS} = 0.0\text{ V}$, $T_A = -40^\circ\text{C to }+85^\circ\text{C}$)

Parameter	Symbol	Pin name	Condition	Value			Unit	Remarks
				Min.	Typ.	Max.		
Clock frequency	F _{CH}	X0, X1	—	3	—	32	MHz	MB90652A/653A
			—	3	—	16	MHz	MB90P653A
	F _{CL}	X0A, X1A	—	—	32.768	—	kHz	
Clock cycle time	t _c	X0, X1	—	31.25	—	333	ns	MB90652A/653A
			—	62.5	—	333	ns	MB90P653A
	t _{cL}	X0A, X1A	—	—	30.5	—	μs	
Input clock pulse width	P _{WH} P _{WL}	X0	—	5	—	—	ns	MB90652A/653A *2
			—	10	—	—	ns	MB90P653A *2
	P _{WLH} P _{WLL}	X0A	—	—	15.2	—	μs	*2
Input clock rise time and fall time	t _{cr} t _{cf}	X0	—	—	—	5	ns	External clock
Internal operating clock frequency	f _{CP}	—	—	1.5	—	16	MHz	MB90652A/653A
			—	1.5	—	8	MHz	MB90P653A
	f _{CPL}	—	—	—	8.192	—	kHz	
Internal operating clock cycle time	t _{CP}	—	—	62.5	—	666	ns	
	t _{CPL}	—	—	—	8.192	—	μs	
Frequency fluctuation ratio	Δf	—	—	—	—	5	%	When locked *1

*1: The frequency fluctuation ratio indicates the maximum fluctuation ratio from the set center frequency while locked when using the PLL multiplier.

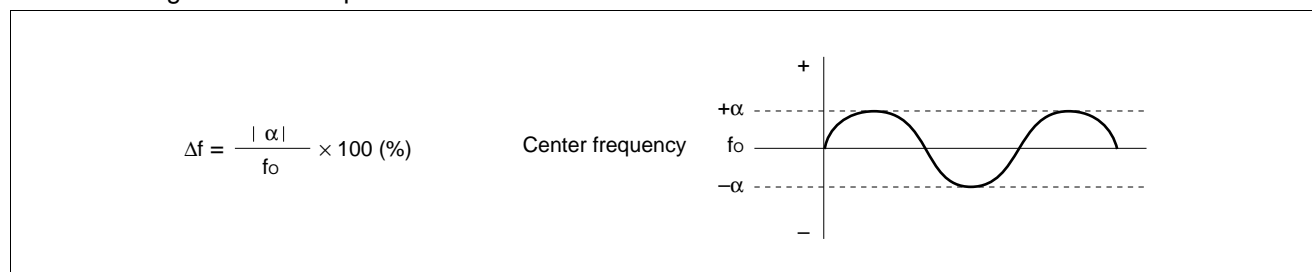

Because the PLL frequency fluctuates around the set frequency with a certain cycle [approximately CLK × (1 CYC to 50 CYC)], the worst value is not maintained for long. (The pulse, if featured with the long period, would produce practically no error.)

*2: The duty ratio should be in the range 30% to 70%.

MB90650A Series

• Main clock timing condition

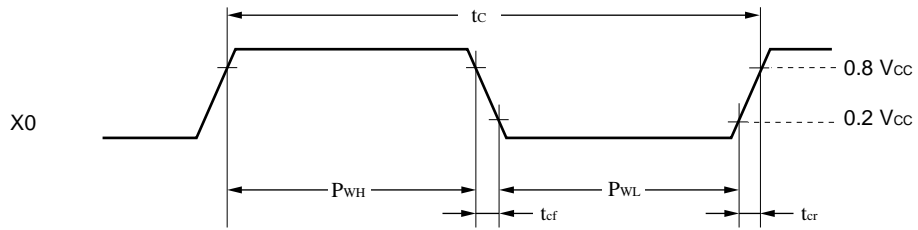

• Subclock timing condition

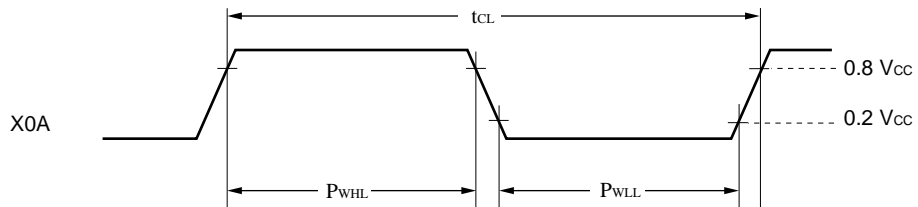

MB90650A Series

• PLL operation assurance range

Relationship between the internal operating clock frequency and supply voltage (MB90652A/653A)

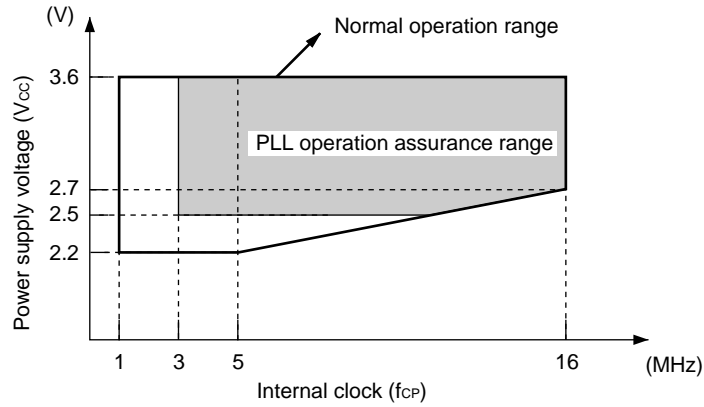

Relationship between the internal operating clock frequency and supply voltage (MB90P653A)

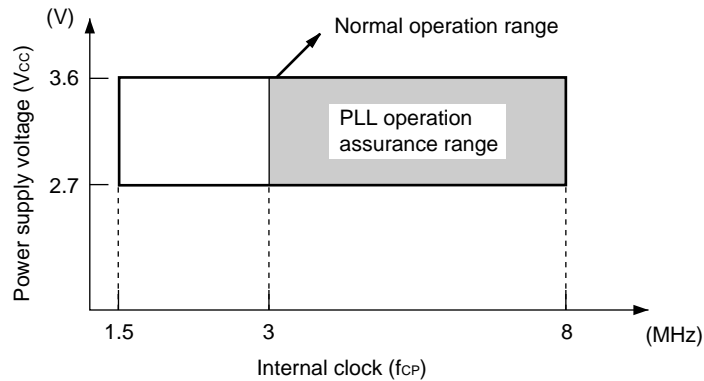

Relationship between the oscillation frequency and internal operating clock frequency

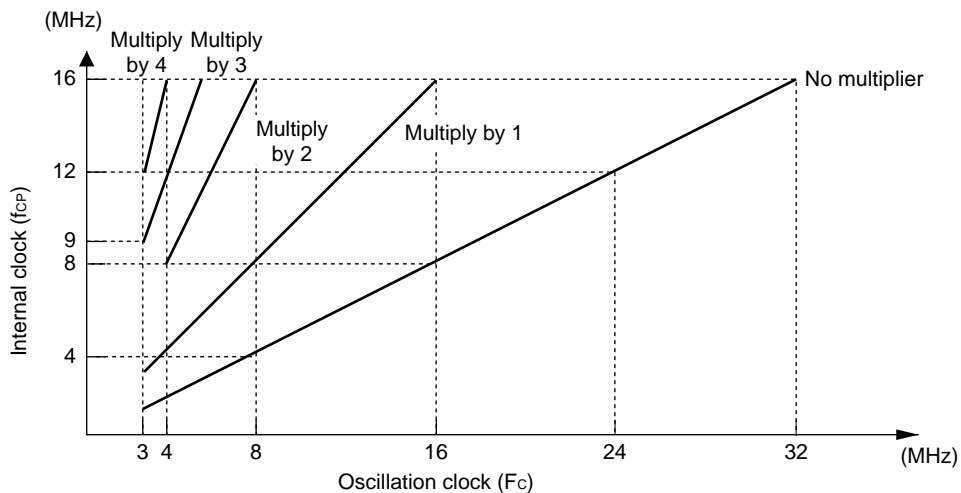

MB90650A Series

The AC characteristics are for the following measurement reference voltages.

• Input signal waveform

Hysteresis input pins

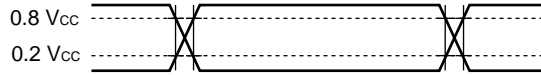

Other than hysteresis or MD input pins

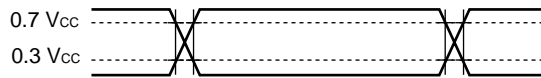

• Output signal waveform

Output pins



MB90650A Series

(2) Clock Output Timing

($V_{CC} = 2.7\text{ V to }3.3\text{ V}$, $V_{SS} = 0.0\text{ V}$, $T_A = -40^\circ\text{C to }+85^\circ\text{C}$)

Parameter	Symbol	Pin name	Condition	Value		Unit	Remarks
				Min.	Max.		
Cycle time	t_{CYC}	CLK	—	t_{CP}	—	ns	
CLK $\uparrow \rightarrow$ CLK \downarrow	t_{CHCL}	CLK	$V_{CC} = 3.0\text{ V}$ $\pm 10\%$	$t_{CP} / 2 - 20$	$t_{CP} / 2 + 20$	ns	In the external frequency of 5 MHz
				$t_{CP} / 2 - 64$	$t_{CP} / 2 + 64$	ns	

t_{CP} : See "(1) Clock Timing."

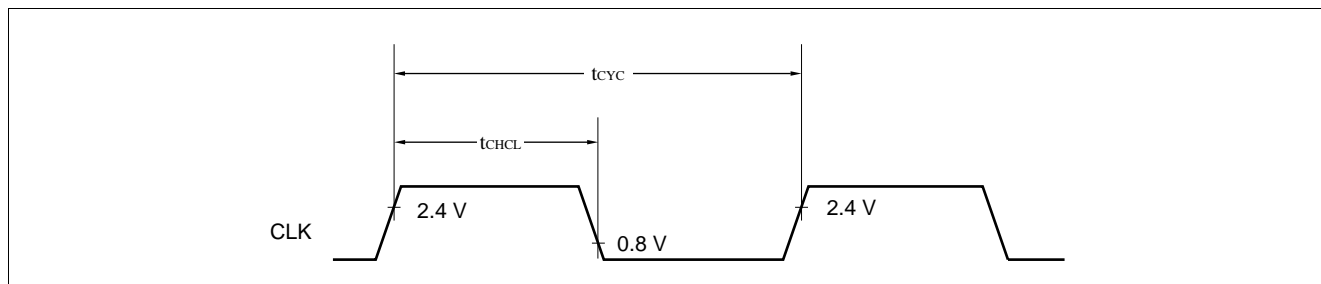

(3) Reset Input Specifications

($V_{CC} = 2.7\text{ V to }3.3\text{ V}$, $V_{SS} = 0.0\text{ V}$, $T_A = -40^\circ\text{C to }+85^\circ\text{C}$)

Parameter	Symbol	Pin name	Condition	Value		Unit	Remarks
				Min.	Max.		
Reset input time	t_{RSTL}	RST	—	$16 t_{CP}$	—	ns	

t_{CP} : See "(1) Clock Timing."

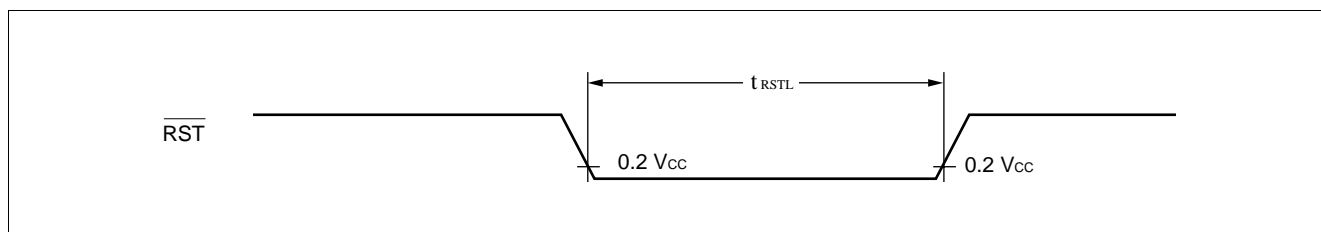

• AC characteristics measurement conditions

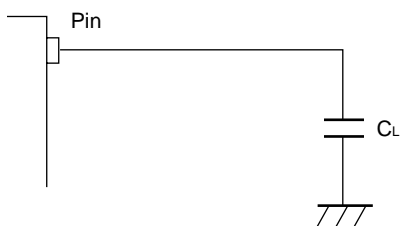

C_L : Load capacitance at testing

CLK, ALE: $C_L = 30\text{ pF}$

AD15 to AD00 (address/data bus), \overline{RD} , \overline{WR} : $C_L = 80\text{ pF}$

MB90650A Series

(5) Power on Supply Specifications (Power-on Reset)

($V_{CC} = 2.7\text{ V to }3.3\text{ V}$, $V_{SS} = 0.0\text{ V}$, $T_A = -40^\circ\text{C to }+85^\circ\text{C}$)

Parameter	Symbol	Pin name	Condition	Value		Unit	Remarks
				Min.	Max.		
Power supply rising time	t_R	V_{CC}	—	—	30	ms	*
Power supply cut-off time	t_{OFF}	V_{CC}	—	1	—	ms	Due to repeat operation

* : When the power rising, V_{CC} must be less than 0.2 V.

Notes: • The above standards are the values needed in order to activate a power-on reset.

• Activate a power-on reset by turning on the power supply again this in device.

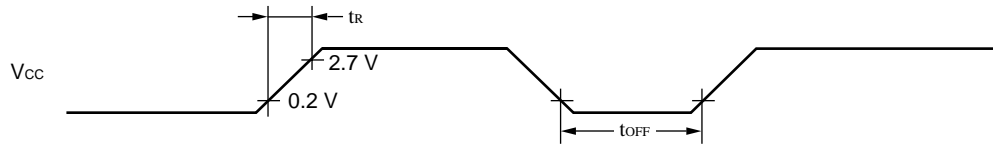

Abrupt changes in the power supply voltage may cause a power-on reset.
When changing the power supply voltage during operation, suppress variations in the voltage and ensure that the voltage rises smoothly, as shown in the following figure.

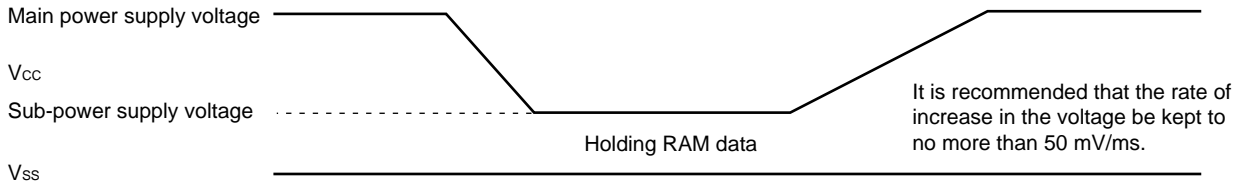

MB90650A Series

(5) Bus Read Timing

($V_{CC} = 2.7\text{ V to }3.3\text{ V}$, $V_{SS} = 0.0\text{ V}$, $T_A = -40^\circ\text{C to }+85^\circ\text{C}$)

Parameter	Symbol	Pin name	Condition	Value		Unit	Remarks
				Min.	Max.		
ALE pulse width	t_{LHLL}	ALE	—	$t_{CP} / 2 - 20$	—	ns	MB90652A/ 653A
				$t_{CP} / 2 - 35$	—	ns	MB90P653A
Valid address → ALE ↓ time	t_{AVLL}	Multiplexed address	—	$t_{CP} / 2 - 25$	—	ns	MB90652A/ 653A
				$t_{CP} / 2 - 40$	—	ns	MB90P653A
ALE ↓ → address valid time	t_{LLAX}	Multiplexed address	—	$t_{CP} / 2 - 15$	—	ns	
Valid address → RD ↓ time	t_{AVRL}	Multiplexed address	—	$t_{CP} - 15$	—	ns	
Valid address → valid data input	t_{AVDV}	Multiplexed address	—	—	$5 t_{CP} / 2 - 60$	ns	MB90652A/ 653A
				—	$5 t_{CP} / 2 - 80$	ns	MB90P653A
RD pulse width	t_{RLRH}	RD	—	$3 t_{CP} / 2 - 20$	—	ns	
RD ↓ → valid data input	t_{RLDV}	D15 to D00	—	—	$5 t_{CP} / 2 - 60$	ns	MB90652A/ 653A
				—	$5 t_{CP} / 2 - 80$	ns	MB90P653A
RD ↑ → data hold time	t_{RHDX}	D15 to D00	—	0	—	ns	
RD ↑ → ALE ↑ time	t_{RHLH}	RD, ALE	—	$t_{CP} / 2 - 15$	—	ns	
RD ↑ → address valid time	t_{RHAX}	Address, RD	—	$t_{CP} / 2 - 10$	—	ns	
Valid address → CLK ↑ time	t_{AVCH}	Address, CLK	—	$t_{CP} / 2 - 20$	—	ns	
RD ↓ → CLK ↑ time	t_{RLCH}	RD, CLK	—	$t_{CP} / 2 - 20$	—	ns	

t_{CP} : See "(1) Clock Timing."

MB90650A Series

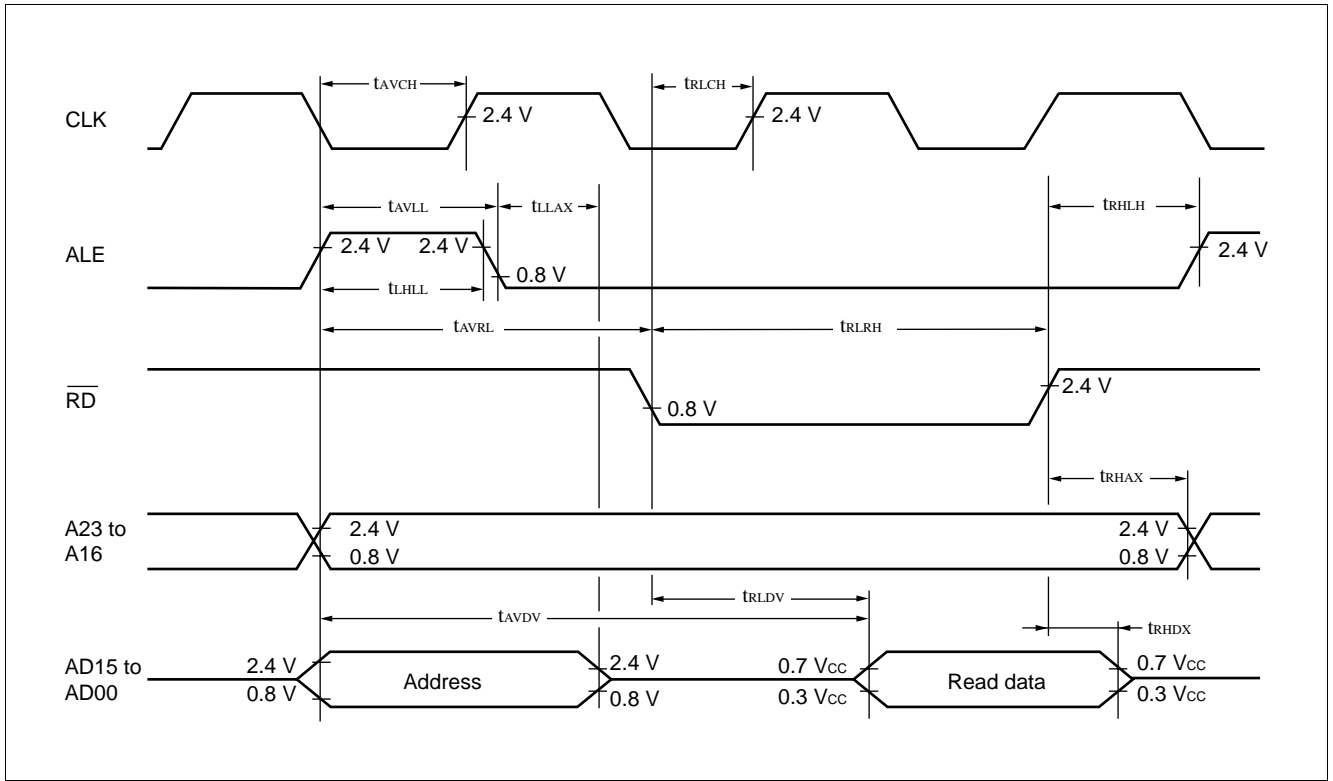

MB90650A Series

(6) Bus Write Timing

($V_{CC} = 2.7\text{ V}$ to 3.3 V , $V_{SS} = 0.0\text{ V}$, $T_A = -40^\circ\text{C}$ to $+85^\circ\text{C}$)

Parameter	Symbol	Pin name	Condition	Value		Unit	Remarks
				Min.	Max.		
Valid address $\rightarrow \overline{WR} \downarrow$ time	t_{AVWL}	A23 to A00	—	$t_{CP} - 15$	—	ns	
\overline{WR} pulse width	t_{WLWH}	\overline{WR}	—	$3 t_{CP} / 2 - 20$	—	ns	
Valid data output $\rightarrow \overline{WR} \uparrow$ time	t_{DVWH}	D15 to D00	—	$3 t_{CP} / 2 - 20$	—	ns	
$\overline{WR} \uparrow \rightarrow$ data hold time	t_{WHDX}	D15 to D00	—	20	—	ns	MB90652A/ 653A
				30	—	ns	MB90P653A
$\overline{WR} \uparrow \rightarrow$ address valid time	t_{WHAX}	A23 to A00	—	$t_{CP} / 2 - 10$	—	ns	
$\overline{WR} \uparrow \rightarrow$ ALE \uparrow time	t_{WHLH}	\overline{WR} , ALE	—	$t_{CP} / 2 - 15$	—	ns	
$\overline{WR} \downarrow \rightarrow$ CLK \uparrow time	t_{WLCH}	\overline{WR} , ALE	—	$t_{CP} / 2 - 20$	—	ns	

t_{CP} : See "(1) Clock Timing."

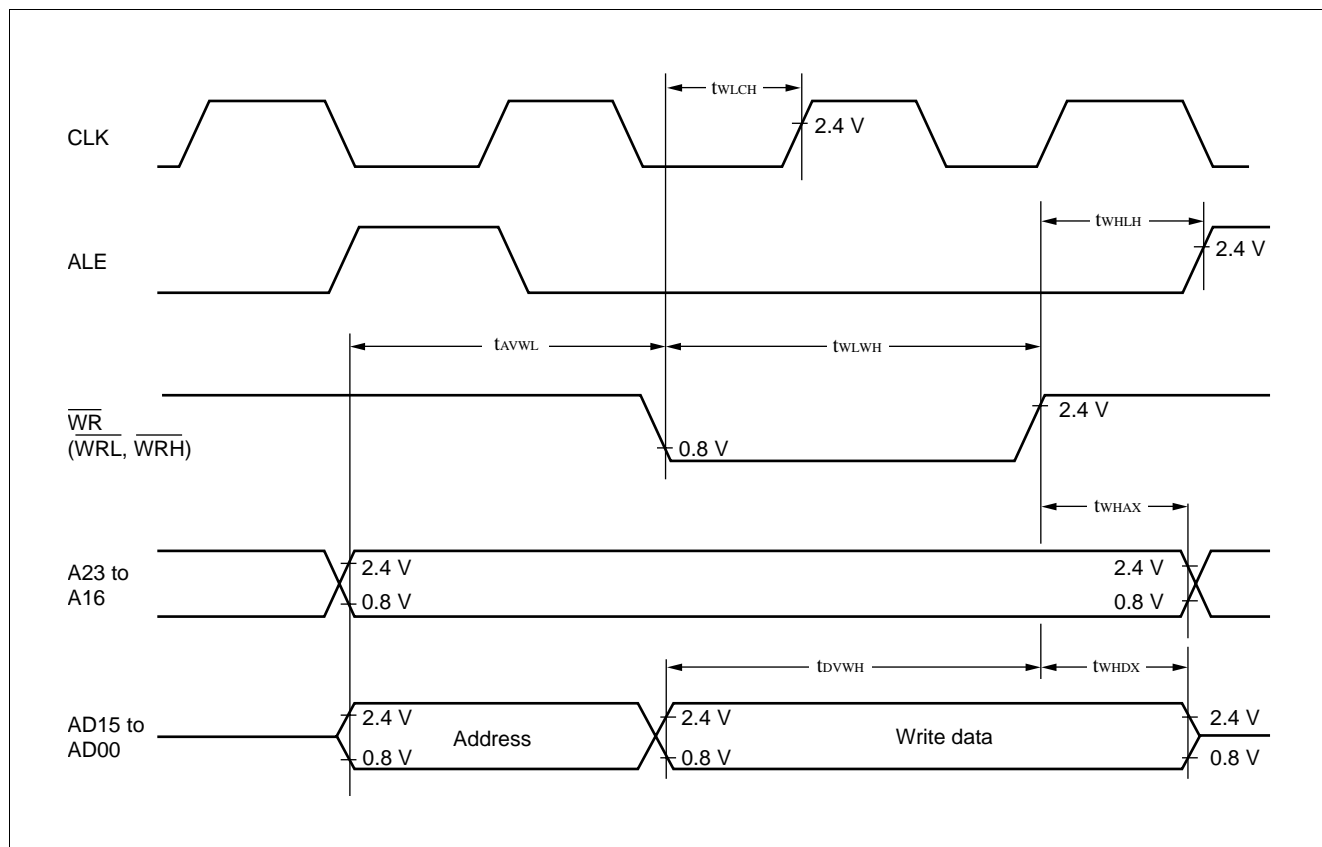

MB90650A Series

(7) Ready Input Timing

($V_{CC} = 2.7\text{ V to }3.3\text{ V}$, $V_{SS} = 0.0\text{ V}$, $T_A = -40^\circ\text{C to }+85^\circ\text{C}$)

Parameter	Symbol	Pin name	Condition	Value		Unit	Remarks
				Min.	Max.		
RDY setup time	t_{RYHS}	RDY	—	45	—	ns	MB90652A/ 653A
			—	70	—	ns	MB90P653A
RDY hold time	t_{RYHH}	RDY	—	0	—	ns	

Note: Use the auto-ready function if the RDY setup time is too short.

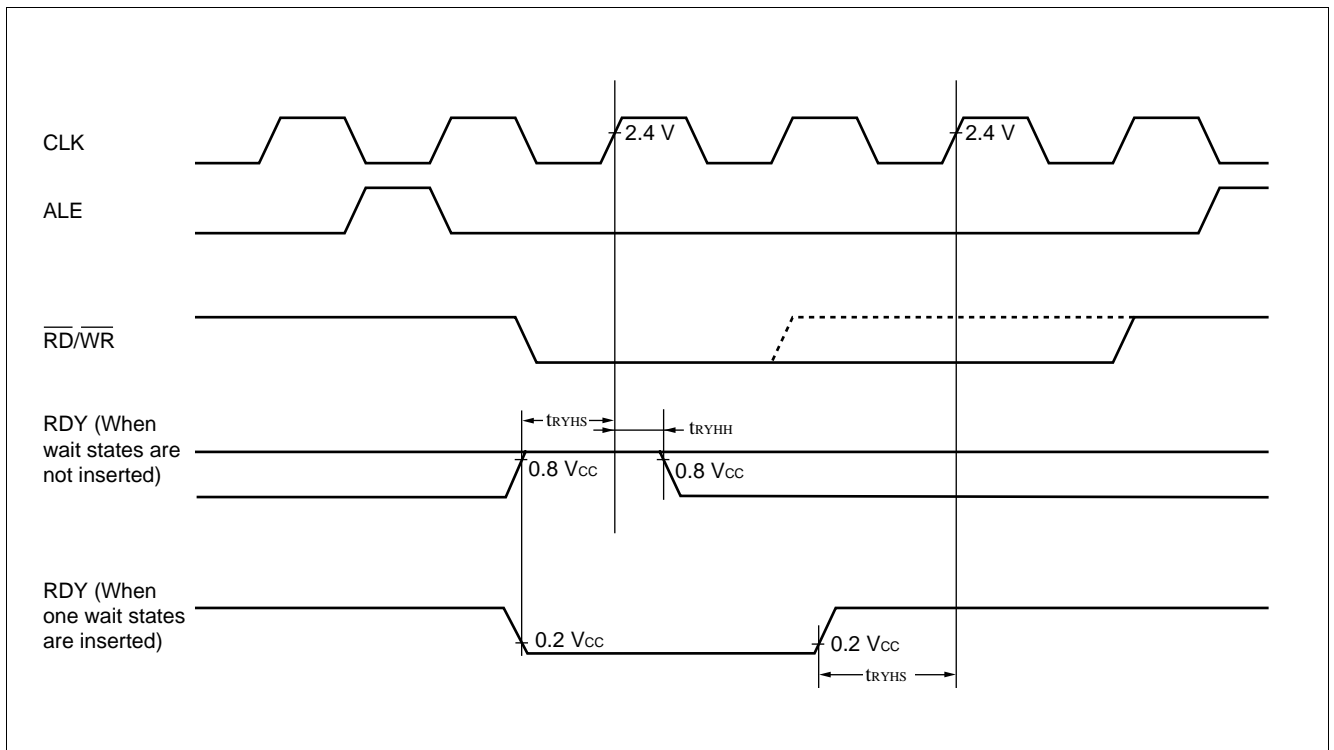

MB90650A Series

(8) Hold Timing

($V_{CC} = 2.7\text{ V to }3.3\text{ V}$, $V_{SS} = 0.0\text{ V}$, $T_A = -40^\circ\text{C to }+85^\circ\text{C}$)

Parameter	Symbol	Pin name	Condition	Value		Unit	Remarks
				Min.	Max.		
Pin floating \rightarrow $\overline{\text{HAK}} \downarrow$ time	$t_{X\text{HAL}}$	$\overline{\text{HAK}}$	—	30	t_{CP}	ns	
$\overline{\text{HAK}} \uparrow \rightarrow$ pin valid time	t_{HAHV}	$\overline{\text{HAK}}$	—	t_{CP}	$2 t_{CP}$	ns	

t_{CP} : See "(1) Clock Timing."

Note: After reading HRQ, more than one cycle is required before changing $\overline{\text{HAK}}$.

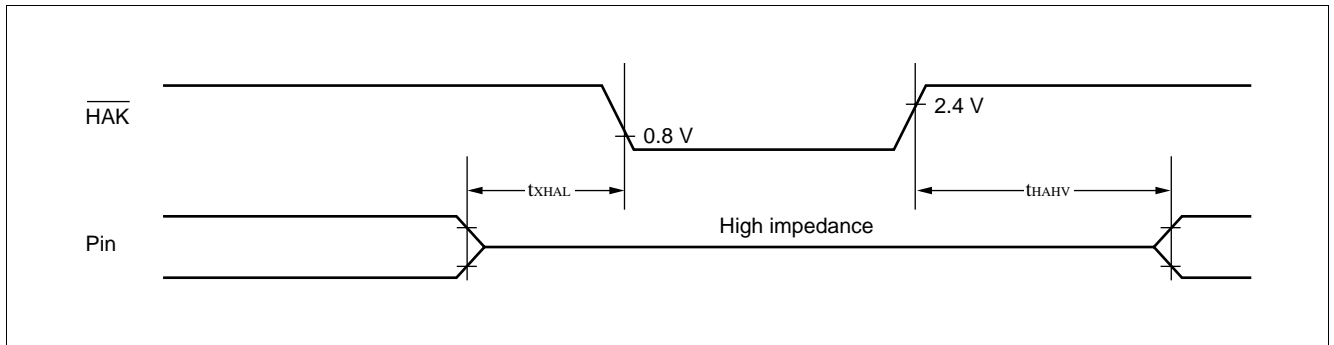

MB90650A Series

(9) UART Timing

($V_{CC} = 2.7\text{ V to }3.3\text{ V}$, $V_{SS} = 0.0\text{ V}$, $T_A = -40^\circ\text{C to }+85^\circ\text{C}$)

Parameter	Symbol	Pin name	Condition	Value		Unit	Remarks
				Min.	Max.		
Serial clock cycle time	t_{SCYC}	—	$C_L = 80\text{ pF} + 1\text{ TTL}$ for the internal shift clock mode output pin	$8 t_{CP}$	—	ns	
SCK ↓ → SOT delay time	t_{SLOV}	—		−80	80	ns	MB90652A/653A
				−120	120	ns	MB90P653A
Valid SIN → SCK ↑	t_{VSH}	—		100	—	ns	MB90652A/653A
				200	—	ns	MB90P653A
SCK ↑ → valid SIN hold time	t_{SHIX}	—	t_{CP}	—	ns		
Serial clock "H" pulse width	t_{SHSL}	—	$C_L = 80\text{ pF} + 1\text{ TTL}$ for the external shift clock mode output pin	$4 t_{CP}$	—	ns	
Serial clock "L" pulse width	t_{LSLH}	—		$4 t_{CP}$	—	ns	
SCK ↓ → SOT delay time	t_{SLOV}	—		—	150	ns	MB90652A/653A
				—	200	ns	MB90P653A
Valid SIN → SCK ↑	t_{VSH}	—		60	—	ns	MB90652A/653A
			120	—	ns	MB90P653A	
SCK ↑ → valid SIN hold time	t_{SHIX}	—	60	—	ns	MB90652A/653A	
			120	—	ns	MB90P653A	

- Notes:
- These are the AC characteristics for CLK synchronous mode.
 - C_L is the load capacitance connected to the pin at testing.
 - t_{CP} is the machine cycle period (unit: ns).

MB90650A Series

• Internal shift clock mode

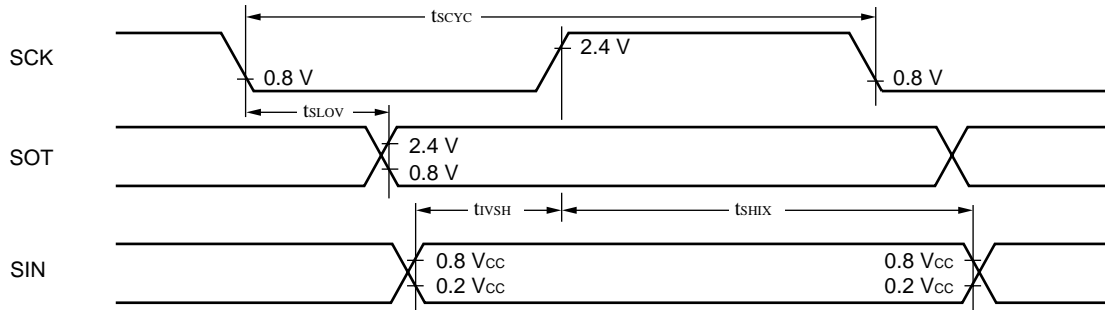

• External shift clock mode

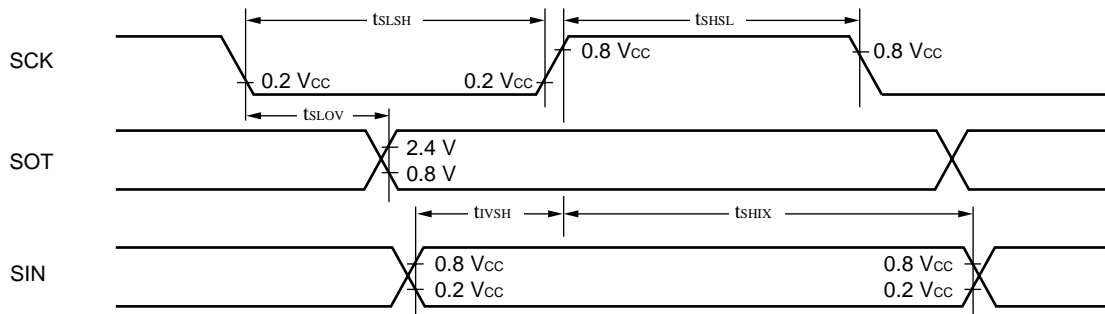

MB90650A Series

(10) I/O Extended Serial Timing

($V_{CC} = 2.7\text{ V to }3.3\text{ V}$, $V_{SS} = 0.0\text{ V}$, $T_A = -40^\circ\text{C to }+85^\circ\text{C}$)

Parameter	Symbol	Pin name	Condition	Value		Unit	Remarks
				Min.	Max.		
Serial clock cycle time	t _{SCYC}	—	C _L = 80 pF + 1 TTL for the internal shift clock mode output pin	8 t _{CP}	—	ns	
SCK ↓ → SOT delay time	t _{SLOV}	—		—	80	ns	MB90652A/653A
Valid SIN → SCK ↑	t _{IVSH}	—		t _{CP}	—	ns	MB90P653A
SCK ↑ → valid SIN hold time	t _{SHIX}	—		t _{CP}	—	ns	
Serial clock "H" pulse width	t _{SHSL}	—	C _L = 80 pF + 1 TTL for the external shift clock mode output pin	230	—	ns	MB90652A/653A
				460	—	ns	MB90P653A
Serial clock "L" pulse width	t _{SLSH}	—		230	—	ns	MB90652A/653A
				460	—	ns	MB90P653A
SCK ↓ → SOT delay time	t _{SLOV}	—		2 t _{CP}	—	ns	
Valid SIN → SCK ↑	t _{IVSH}	—		t _{CP}	—	ns	
SCK ↑ → valid SIN hold time	t _{SHIX}	—		2 t _{CP}	—	ns	

- Notes:
- These are the AC characteristics for CLK synchronous mode.
 - C_L is the load capacitance connected to the pin at testing.
 - t_{CP} is the machine cycle period (unit: ns).
 - The values in the table are target values.

MB90650A Series

• Internal shift clock mode

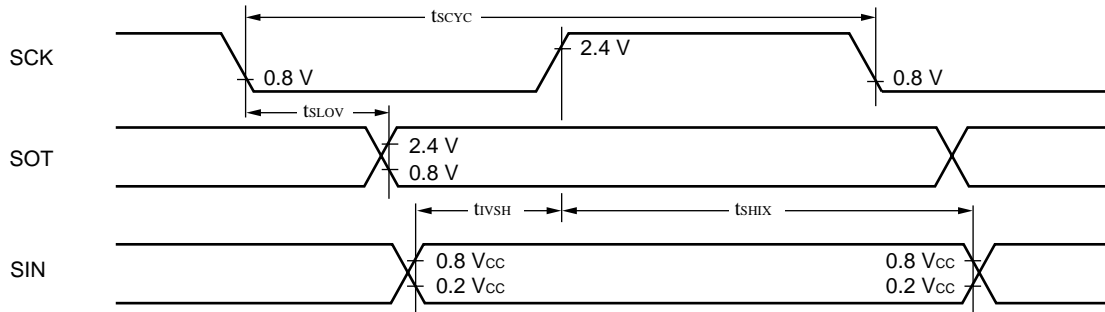

• External shift clock mode

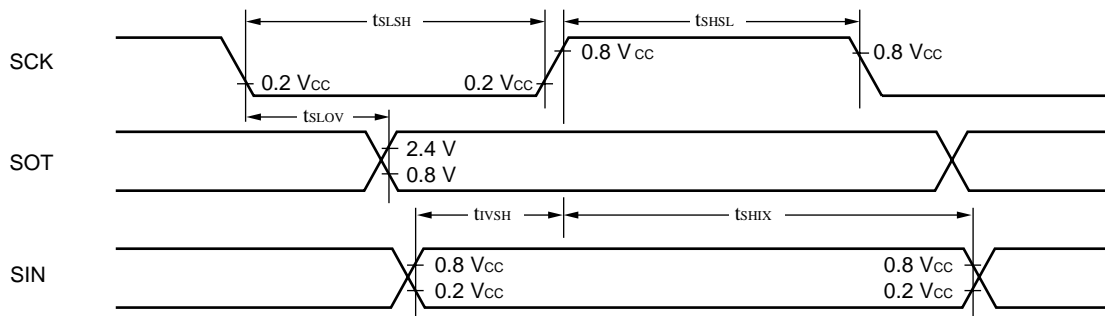

MB90650A Series

(11) I²C Timing

($V_{CC} = 2.7\text{ V to }3.3\text{ V}$, $V_{SS} = 0.0\text{ V}$, $T_A = -40^\circ\text{C to }+85^\circ\text{C}$)

Parameter	Symbol	Pin name	Condition	Value		Unit	Remarks
				Min.	Max.		
SCL clock frequency	f_{SCL}	—	—	0	100	kHz	
Bus free time between stop and start conditions	t_{BUS}	—	—	4.7	—	μs	
Hold time (re-send) start	t_{HDSTA}	—	—	4.0	—	μs	The first clock pulse is generated after this period.
SCL clock L state hold time	t_{LOW}	—	—	4.7	—	μs	
SCL clock H state hold time	t_{HIGH}	—	—	4.0	—	μs	
Re-send start condition setup time	t_{SUSTA}	—	—	4.7	—	μs	
Data hold time	t_{HDDAT}	—	—	0	—	μs	
Data setup time	t_{SUDAT}	—	—	250	—	ns	
SDA and SCL signal rising time	t_R	—	—	—	1000	ns	
SDA and SCL signal falling time	t_F	—	—	—	300	ns	
Stop condition setup time	t_{SUSTO}	—	—	4.0	—	μs	

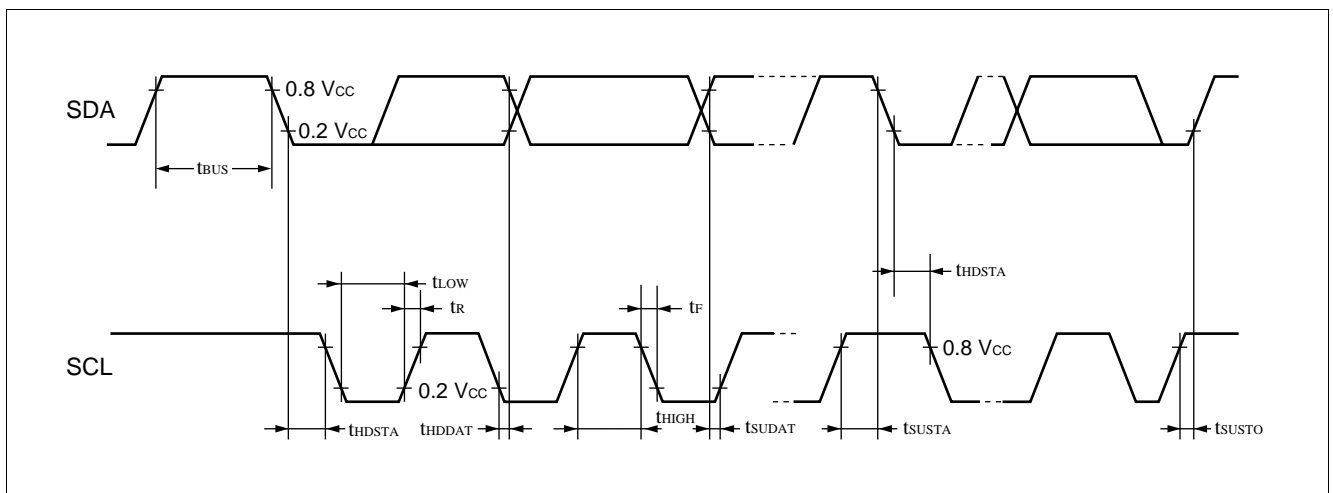

MB90650A Series

5. A/D Converter Electrical Characteristics

(MB90652A/653A: $AV_{CC} = V_{CC} = 2.2 \text{ V to } 3.3 \text{ V}$, $AV_{SS} = V_{SS} = 0.0 \text{ V}$, $2.7 \text{ V} \leq AVR_H - AVR_L$, $T_A = -40^\circ\text{C to } +85^\circ\text{C}$)

(MB90P653A: $AV_{CC} = V_{CC} = 2.7 \text{ V to } 3.3 \text{ V}$, $AV_{SS} = V_{SS} = 0.0 \text{ V}$, $2.7 \text{ V} \leq AVR_H - AVR_L$, $T_A = -40^\circ\text{C to } +85^\circ\text{C}$)

Parameter	Symbol	Pin name	Value			Unit	Remarks
			Min.	Typ.	Max.		
Resolution	—	—	—	10	10	bit	
Total error	—	—	—	—	± 4.0	LSB	MB90652A/ 653A
			—	—	± 3.0	LSB	MB90P653A
Linearity error	—	—	—	—	± 2.0	LSB	
Differential linearity error	—	—	—	—	± 1.9	LSB	MB90652A/ 653A
			—	—	± 1.5	LSB	MB90P653A
Zero transition voltage	V_{OT}	AN0 to AN7	$AVRL - 1.5 \text{ LSB}$	$AVRL + 0.5 \text{ LSB}$	$AVRL + 2.5 \text{ LSB}$	mV	
Full scale transition voltage	V_{FST}	AN0 to AN7	$AVRH - 4.5 \text{ LSB}$	$AVRH - 1.5 \text{ LSB}$	$AVRH + 0.5 \text{ LSB}$	mV	
Conversion time	—	—	6.125^{*1}	—	—	μs	MB90652A/ 653A
			12.25^{*2}	—	—	μs	MB90P653A
Analog port input current	I_{AIN}	AN0 to AN7	—	0.1	10	μA	
Analog input voltage	V_{AIN}	AN0 to AN7	AVRL	—	AVRH	V	
Reference voltage	—	AVRH	$AVRL + 2.7$	—	AV_{CC}	V	
		AVRL	0	—	$AVRH - 2.7$	V	
Power supply current	I_A	AV_{CC}	—	3	—	mA	
	I_{AH}	AV_{CC}	—	—	5^{*3}	μA	
Reference voltage supply current	I_R	AVRH	—	200	—	μA	
	I_{RH}	AVRH	—	—	5^{*3}	μA	
Variation between channels	—	AN0 to AN7	—	—	4	LSB	

*1: For a 16 MHz machine clock

*2: For an 8 MHz machine clock

*3: The current when the A/D converter is not operating or the CPU is in stop mode (for $V_{CC} = AV_{CC} = AVR_H = 3.0 \text{ V}$).

- Notes:
- The error increases proportionally as $|AVRH - AVR_L|$ decreases.
 - The output impedance of the external circuits connected to the analog inputs should be in the following range.
The output impedance of the external circuit should be less than approximately $7 \text{ k}\Omega$.
When using an external capacitor, it is recommended to have several thousand times the capacitance of the internal capacitor as a guide, if one takes into consideration the effect of the divided capacitance between the external capacitor and the internal capacitor.
 - If the output impedance of the external circuit is too high, the sampling time might be insufficient (sampling time = $3.75 \mu\text{s}$ @ at a machine clock of 16 MHz).

MB90650A Series

• Analog input circuit model diagram

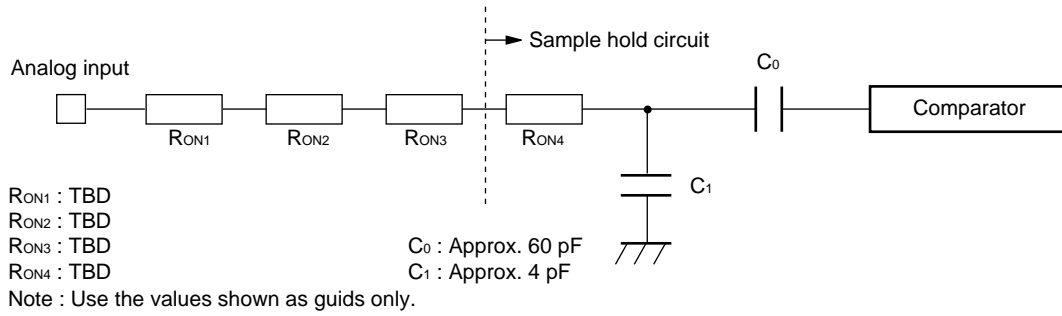

MB90650A Series

6. D/A Converter Electrical Characteristics

(MB90652A/653A: $V_{CC} = 2.2\text{ V to } 3.3\text{ V}$, $DV_{SS} = V_{SS} = 0.0\text{ V}$, $2.2\text{ V} \leq \text{DVRH} - DV_{SS}$, $T_A = -40^\circ\text{C to } +85^\circ\text{C}$)

(MB90P653A: $V_{CC} = 2.7\text{ V to } 3.3\text{ V}$, $DV_{SS} = V_{SS} = 0.0\text{ V}$, $2.7\text{ V} \leq \text{DVRH} - DV_{SS}$, $T_A = -40^\circ\text{C to } +85^\circ\text{C}$)

Parameter	Symbol	Pin name	Value			Unit	Remarks
			Min.	Typ.	Max.		
Resolution	—	—	—	8	8	bit	
Differential linearity error	—	—	—	—	± 0.9	LSB	
Absolute accuracy	—	—	—	—	1	%	
Linearity error	—	—	—	—	± 1.5	LSB	
Conversion time	—	—	—	10.0	20.0	μs	*1
Analog reference power supply voltage	—	DVRH	2.2	—	V_{CC}	V	MB90652A/653A *2
			2.7	—	V_{CC}	V	MB90P653A *2
Reference voltage supply current	I_{DVR}	DVRH	—	100	—	μA	*3
	I_{DVRs}		—	—	5	μA	*4
Analog output impedance	—	—	—	28	—	$\text{k}\Omega$	

*1: Conversion time is the value at the load capacitance = 20 pF.

*2: $\text{DVRH} - DV_{SS}$ (AV_{SS})

*3: Current value at conversion

*4: Current value when stopped

MB90650A Series

EXAMPLE CHARACTERISTICS

(1) "H" Level Output Voltage

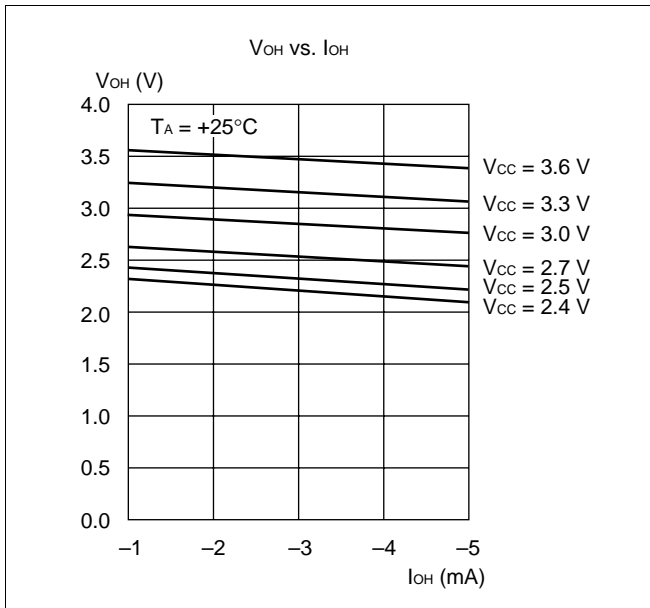

(2) "L" Level Output Voltage

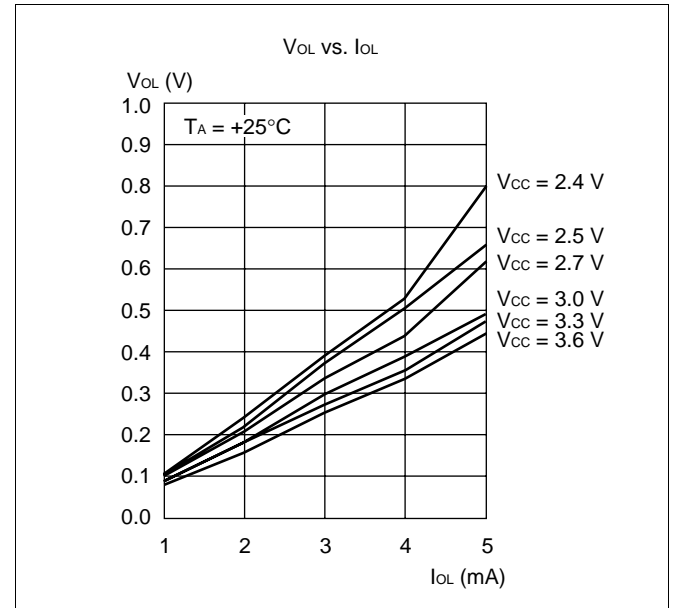

(3) "H" Level Input Voltage/"L" Level Input Voltage (COMS Input)

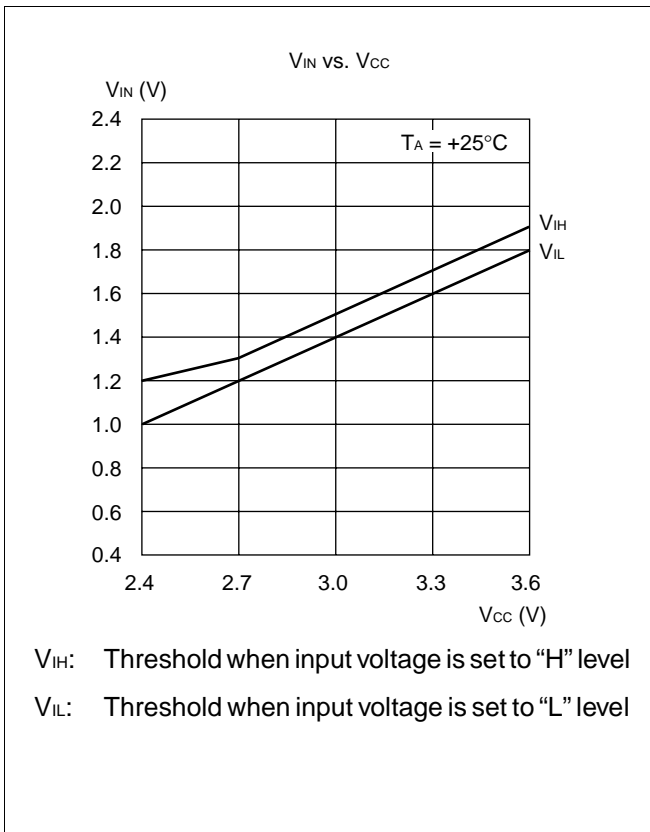

(4) "H" Level Input Voltage/"L" Level Input Voltage (Hysteresis Input)

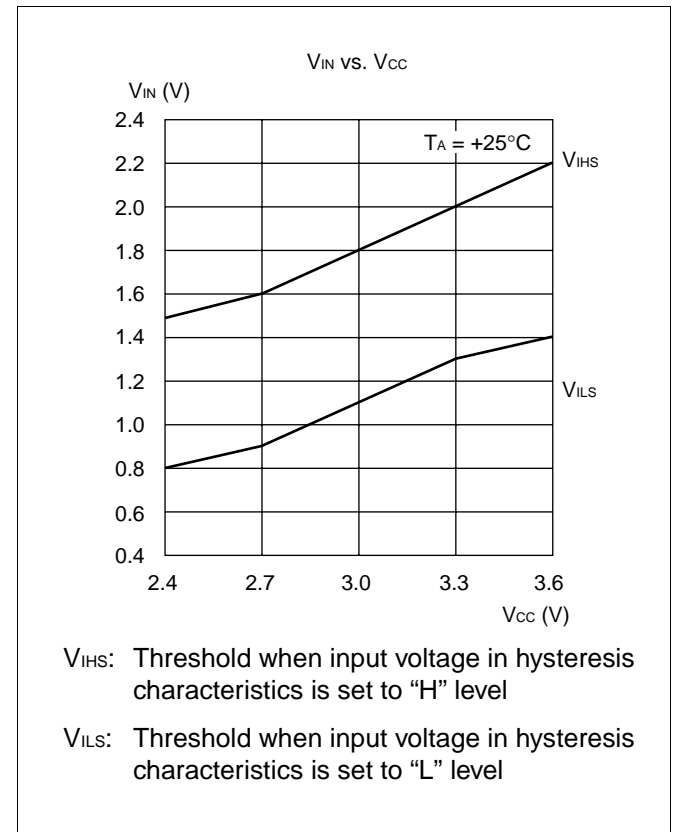

(5) Power Supply Current (f_{CP} = Internal Operating Clock Frequency)

• Mask ROM products

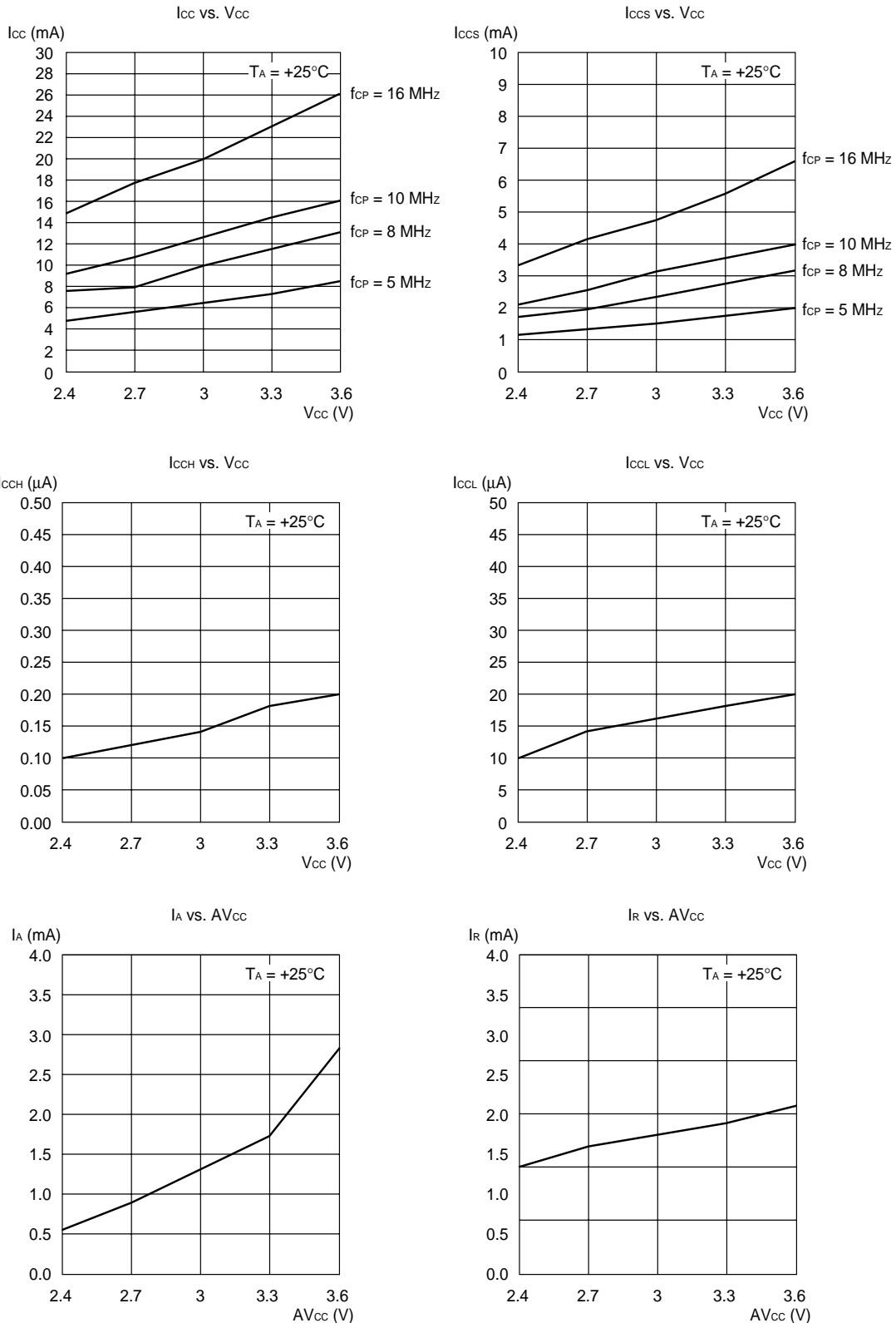

MB90650A Series

• OTPROM products

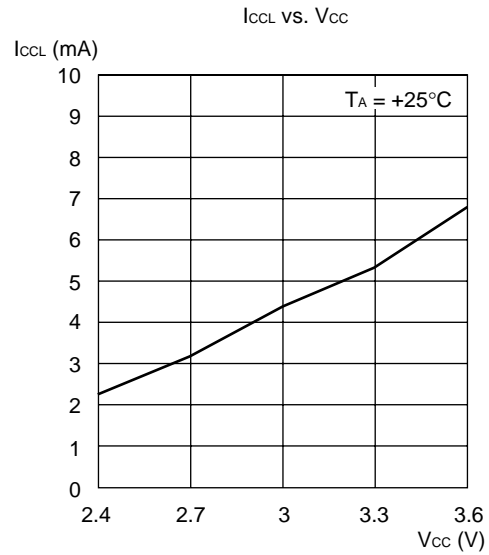
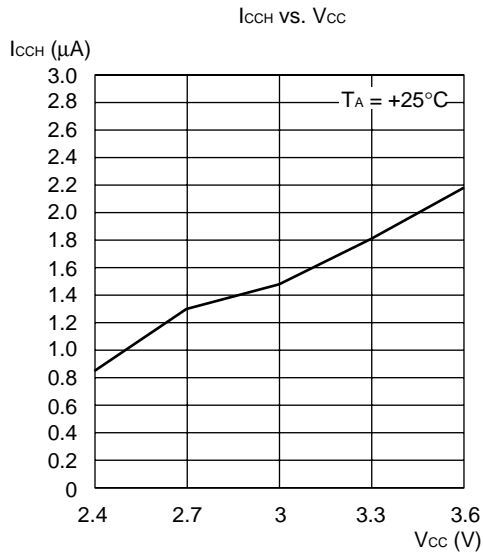
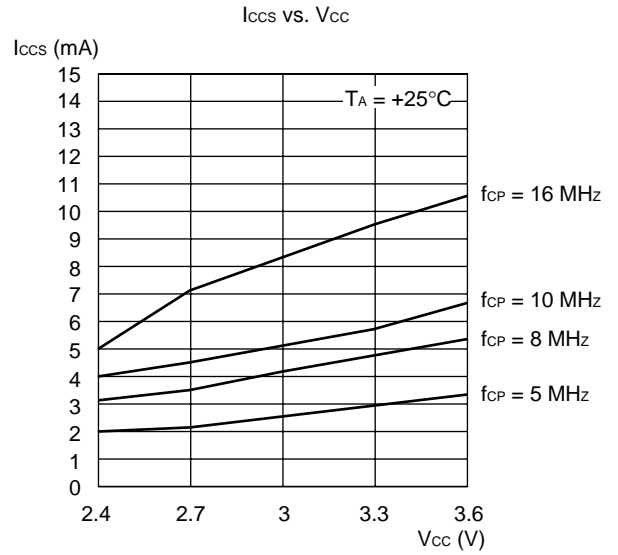
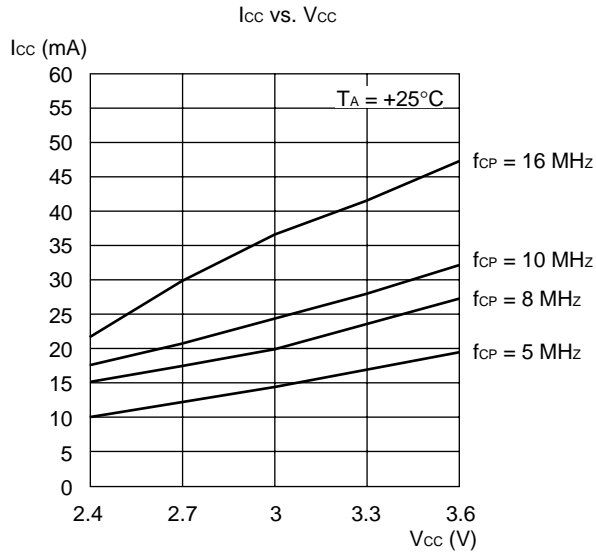

MB90650A Series

(6) Pull-up Resistance

- Mask ROM products

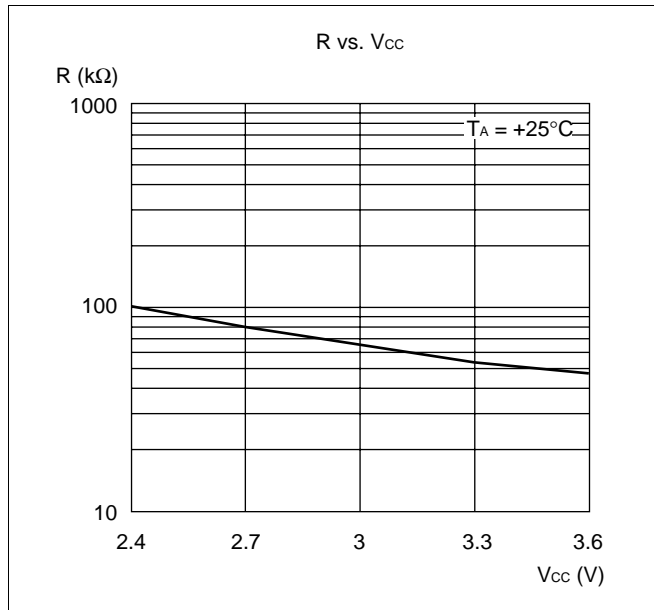

- OTPROM products

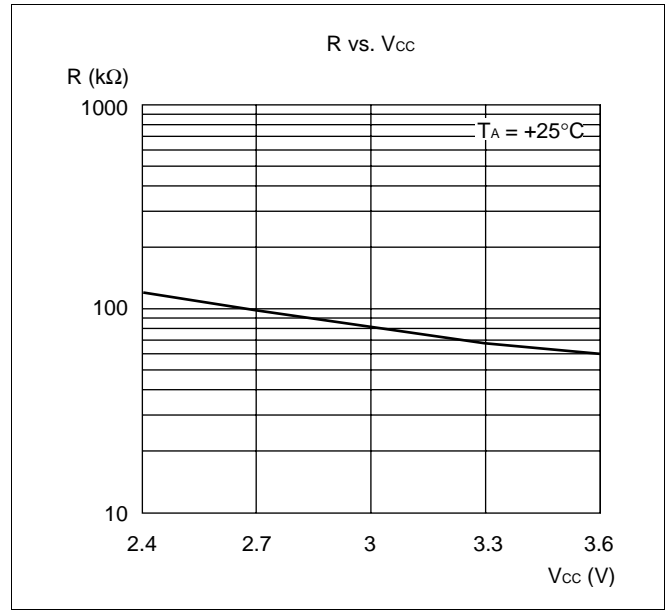

MB90650A Series

■ INSTRUCTIONS (340 INSTRUCTIONS)

Table 1 Explanation of Items in Tables of Instructions

Item	Meaning
Mnemonic	Upper-case letters and symbols: Represented as they appear in assembler. Lower-case letters: Replaced when described in assembler. Numbers after lower-case letters: Indicate the bit width within the instruction.
#	Indicates the number of bytes.
~	Indicates the number of cycles. m: When branching n : When not branching See Table 4 for details about meanings of other letters in items.
RG	Indicates the number of accesses to the register during execution of the instruction. It is used calculate a correction value for intermittent operation of CPU.
B	Indicates the correction value for calculating the number of actual cycles during execution of the instruction. (Table 5) The number of actual cycles during execution of the instruction is the correction value summed with the value in the “~” column.
Operation	Indicates the operation of instruction.
LH	Indicates special operations involving the upper 8 bits of the lower 16 bits of the accumulator. Z : Transfers “0”. X : Extends with a sign before transferring. – : Transfers nothing.
AH	Indicates special operations involving the upper 16 bits in the accumulator. * : Transfers from AL to AH. – : No transfer. Z : Transfers 00 _H to AH. X : Transfers 00 _H or FF _H to AH by signing and extending AL.
I	Indicates the status of each of the following flags: I (interrupt enable), S (stack), T (sticky bit), N (negative), Z (zero), V (overflow), and C (carry). * : Changes due to execution of instruction. – : No change. S : Set by execution of instruction. R : Reset by execution of instruction.
S	
T	
N	
Z	
V	
C	
RMW	Indicates whether the instruction is a read-modify-write instruction. (a single instruction that reads data from memory, etc., processes the data, and then writes the result to memory.) * : Instruction is a read-modify-write instruction. – : Instruction is not a read-modify-write instruction. Note: A read-modify-write instruction cannot be used on addresses that have different meanings depending on whether they are read or written.

MB90650A Series

Table 2 Explanation of Symbols in Tables of Instructions

Symbol	Meaning
A	32-bit accumulator The bit length varies according to the instruction. Byte : Lower 8 bits of AL Word : 16 bits of AL Long : 32 bits of AL:AH
AH AL	Upper 16 bits of A Lower 16 bits of A
SP	Stack pointer (USP or SSP)
PC	Program counter
PCB	Program bank register
DTB	Data bank register
ADB	Additional data bank register
SSB	System stack bank register
USB	User stack bank register
SPB	Current stack bank register (SSB or USB)
DPR	Direct page register
brg1	DTB, ADB, SSB, USB, DPR, PCB, SPB
brg2	DTB, ADB, SSB, USB, DPR, SPB
Ri	R0, R1, R2, R3, R4, R5, R6, R7
RWi	RW0, RW1, RW2, RW3, RW4, RW5, RW6, RW7
RWj	RW0, RW1, RW2, RW3
RLi	RL0, RL1, RL2, RL3
dir	Compact direct addressing
addr16 addr24 ad24 0 to 15 ad24 16 to 23	Direct addressing Physical direct addressing Bit 0 to bit 15 of addr24 Bit 16 to bit 23 of addr24
io	I/O area (000000 _H to 0000FF _H)
imm4 imm8 imm16 imm32 ext (imm8)	4-bit immediate data 8-bit immediate data 16-bit immediate data 32-bit immediate data 16-bit data signed and extended from 8-bit immediate data
disp8 disp16	8-bit displacement 16-bit displacement
bp	Bit offset
vct4 vct8	Vector number (0 to 15) Vector number (0 to 255)
()b	Bit address

(Continued)

MB90650A Series

(Continued)

Symbol	Meaning
rel	Branch specification relative to PC
ear	Effective addressing (codes 00 to 07)
eam	Effective addressing (codes 08 to 1F)
rlst	Register list

Table 3 Effective Address Fields

Code	Notation			Address format	Number of bytes in address extension *	
00	R0	RW0	RL0	Register direct	—	
01	R1	RW1	(RL0)	"ea" corresponds to byte, word, and long-word types, starting from the left		
02	R2	RW2	RL1			
03	R3	RW3	(RL1)			
04	R4	RW4	RL2			
05	R5	RW5	(RL2)			
06	R6	RW6	RL3			
07	R7	RW7	(RL3)			
08	@RW0				Register indirect	0
09	@RW1			Register indirect with post-increment		
0A	@RW2					
0B	@RW3					
0C	@RW0 +				Register indirect with 8-bit displacement	1
0D	@RW1 +					
0E	@RW2 +					
0F	@RW3 +					
10	@RW0 + disp8			Register indirect with 16-bit displacement	2	
11	@RW1 + disp8					
12	@RW2 + disp8					
13	@RW3 + disp8					
14	@RW4 + disp8				0	
15	@RW5 + disp8					
16	@RW6 + disp8					
17	@RW7 + disp8					
18	@RW0 + disp16			Register indirect with index	0	
19	@RW1 + disp16					
1A	@RW2 + disp16				PC indirect with 16-bit displacement	2
1B	@RW3 + disp16					
1C	@RW0 + RW7			Register indirect with index	0	
1D	@RW1 + RW7			Register indirect with index	0	
1E	@PC + disp16			PC indirect with 16-bit displacement	2	
1F	addr16			Direct address	2	

Note: The number of bytes in the address extension is indicated by the "+" symbol in the "#" (number of bytes) column in the tables of instructions.

MB90650A Series

Table 4 Number of Execution Cycles for Each Type of Addressing

Code	Operand	(a)	Number of register accesses for each type of addressing
		Number of execution cycles for each type of addressing	
00 to 07	Ri RWi RLi	Listed in tables of instructions	Listed in tables of instructions
08 to 0B	@RWj	2	1
0C to 0F	@RWj +	4	2
10 to 17	@RWi + disp8	2	1
18 to 1B	@RWj + disp16	2	1
1C	@RW0 + RW7	4	2
1D	@RW1 + RW7	4	2
1E	@PC + disp16	2	0
1F	addr16	1	0

Note: “(a)” is used in the “~” (number of states) column and column B (correction value) in the tables of instructions.

Table 5 Correction Values for Number of Cycles Used to Calculate Number of Actual Cycles

Operand	(b) byte		(c) word		(d) long	
	Number of cycles	Number of access	Number of cycles	Number of access	Number of cycles	Number of access
Internal register	+0	1	+0	1	+0	2
Internal memory even address	+0	1	+0	1	+0	2
Internal memory odd address	+0	1	+2	2	+4	4
Even address on external data bus (16 bits)	+1	1	+1	1	+2	2
Odd address on external data bus (16 bits)	+1	1	+4	2	+8	4
External data bus (8 bits)	+1	1	+4	2	+8	4

Notes: • “(b)”, “(c)”, and “(d)” are used in the “~” (number of states) column and column B (correction value) in the tables of instructions.

- When the external data bus is used, it is necessary to add in the number of wait cycles used for ready input and automatic ready.

Table 6 Correction Values for Number of Cycles Used to Calculate Number of Program Fetch Cycles

Instruction	Byte boundary	Word boundary
Internal memory	—	+2
External data bus (16 bits)	—	+3
External data bus (8 bits)	+3	—

Notes: • When the external data bus is used, it is necessary to add in the number of wait cycles used for ready input and automatic ready.

- Because instruction execution is not slowed down by all program fetches in actuality, these correction values should be used for “worst case” calculations.

MB90650A Series

Table 7 Transfer Instructions (Byte) [41 Instructions]

Mnemonic	#	~	RG	B	Operation	LH	AH	I	S	T	N	Z	V	C	RMW
MOV A, dir	2	3	0	(b)	byte (A) ← (dir)	Z	*	—	—	—	*	*	—	—	—
MOV A, addr16	3	4	0	(b)	byte (A) ← (addr16)	Z	*	—	—	—	*	*	—	—	—
MOV A, Ri	1	2	1	0	byte (A) ← (Ri)	Z	*	—	—	—	*	*	—	—	—
MOV A, ear	2	2	1	0	byte (A) ← (ear)	Z	*	—	—	—	*	*	—	—	—
MOV A, eam	2+	3+ (a)	0	(b)	byte (A) ← (eam)	Z	*	—	—	—	*	*	—	—	—
MOV A, io	2	3	0	(b)	byte (A) ← (io)	Z	*	—	—	—	*	*	—	—	—
MOV A, #imm8	2	2	0	0	byte (A) ← imm8	Z	*	—	—	—	*	*	—	—	—
MOV A, @A	2	3	0	(b)	byte (A) ← ((A))	Z	—	—	—	—	*	*	—	—	—
MOV A, @RLi+disp8	3	10	2	(b)	byte (A) ← ((RLi)+disp8)	Z	*	—	—	—	*	*	—	—	—
MOVN A, #imm4	1	1	0	0	byte (A) ← imm4	Z	*	—	—	—	R	*	—	—	—
MOVX A, dir	2	3	0	(b)	byte (A) ← (dir)	X	*	—	—	—	*	*	—	—	—
MOVX A, addr16	3	4	0	(b)	byte (A) ← (addr16)	X	*	—	—	—	*	*	—	—	—
MOVX A, Ri	2	2	1	0	byte (A) ← (Ri)	X	*	—	—	—	*	*	—	—	—
MOVX A, ear	2	2	1	0	byte (A) ← (ear)	X	*	—	—	—	*	*	—	—	—
MOVX A, eam	2+	3+ (a)	0	(b)	byte (A) ← (eam)	X	*	—	—	—	*	*	—	—	—
MOVX A, io	2	3	0	(b)	byte (A) ← (io)	X	*	—	—	—	*	*	—	—	—
MOVX A, #imm8	2	2	0	0	byte (A) ← imm8	X	*	—	—	—	*	*	—	—	—
MOVX A, @A	2	3	0	(b)	byte (A) ← ((A))	X	—	—	—	—	*	*	—	—	—
MOVX A, @RWi+disp8	2	5	1	(b)	byte (A) ← ((RWi)+disp8)	X	*	—	—	—	*	*	—	—	—
MOVX A, @RLi+disp8	3	10	2	(b)	byte (A) ← ((RLi)+disp8)	X	*	—	—	—	*	*	—	—	—
MOV dir, A	2	3	0	(b)	byte (dir) ← (A)	—	—	—	—	—	*	*	—	—	—
MOV addr16, A	3	4	0	(b)	byte (addr16) ← (A)	—	—	—	—	—	*	*	—	—	—
MOV Ri, A	1	2	1	0	byte (Ri) ← (A)	—	—	—	—	—	*	*	—	—	—
MOV ear, A	2	2	1	0	byte (ear) ← (A)	—	—	—	—	—	*	*	—	—	—
MOV eam, A	2+	3+ (a)	0	(b)	byte (eam) ← (A)	—	—	—	—	—	*	*	—	—	—
MOV io, A	2	3	0	(b)	byte (io) ← (A)	—	—	—	—	—	*	*	—	—	—
MOV @RLi+disp8, A	3	10	2	(b)	byte ((RLi) +disp8) ← (A)	—	—	—	—	—	*	*	—	—	—
MOV Ri, ear	2	3	2	0	byte (Ri) ← (ear)	—	—	—	—	—	*	*	—	—	—
MOV Ri, eam	2+	4+ (a)	1	(b)	byte (Ri) ← (eam)	—	—	—	—	—	*	*	—	—	—
MOV ear, Ri	2	4	2	0	byte (ear) ← (Ri)	—	—	—	—	—	*	*	—	—	—
MOV eam, Ri	2+	5+ (a)	1	(b)	byte (eam) ← (Ri)	—	—	—	—	—	*	*	—	—	—
MOV Ri, #imm8	2	2	1	0	byte (Ri) ← imm8	—	—	—	—	—	*	*	—	—	—
MOV io, #imm8	3	5	0	(b)	byte (io) ← imm8	—	—	—	—	—	—	—	—	—	—
MOV dir, #imm8	3	5	0	(b)	byte (dir) ← imm8	—	—	—	—	—	—	—	—	—	—
MOV ear, #imm8	3	2	1	0	byte (ear) ← imm8	—	—	—	—	—	*	*	—	—	—
MOV eam, #imm8	3+	4+ (a)	0	(b)	byte (eam) ← imm8	—	—	—	—	—	—	—	—	—	—
MOV @AL, AH	2	3	0	(b)	byte ((A)) ← (AH)	—	—	—	—	—	*	*	—	—	—
XCH A, ear	2	4	2	0	byte (A) ↔ (ear)	Z	—	—	—	—	—	—	—	—	—
XCH A, eam	2+	5+ (a)	0	2× (b)	byte (A) ↔ (eam)	Z	—	—	—	—	—	—	—	—	—
XCH Ri, ear	2	7	4	0	byte (Ri) ↔ (ear)	—	—	—	—	—	—	—	—	—	—
XCH Ri, eam	2+	9+ (a)	2	2× (b)	byte (Ri) ↔ (eam)	—	—	—	—	—	—	—	—	—	—

Note: For an explanation of “(a)” to “(d)”, refer to Table 4, “Number of Execution Cycles for Each Type of Addressing,” and Table 5, “Correction Values for Number of Cycles Used to Calculate Number of Actual Cycles.”

MB90650A Series

Table 8 Transfer Instructions (Word/Long Word) [38 Instructions]

Mnemonic	#	~	RG	B	Operation	LH	AH	I	S	T	N	Z	V	C	RMW
MOVW A, dir	2	3	0	(c)	word (A) ← (dir)	—	*	—	—	—	*	*	—	—	—
MOVW A, addr16	3	4	0	(c)	word (A) ← (addr16)	—	*	—	—	—	*	*	—	—	—
MOVW A, SP	1	1	0	0	word (A) ← (SP)	—	*	—	—	—	*	*	—	—	—
MOVW A, RWi	1	2	1	0	word (A) ← (RWi)	—	*	—	—	—	*	*	—	—	—
MOVW A, ear	2	2	1	0	word (A) ← (ear)	—	*	—	—	—	*	*	—	—	—
MOVW A, eam	2+	3+ (a)	0	(c)	word (A) ← (eam)	—	*	—	—	—	*	*	—	—	—
MOVW A, io	2	3	0	(c)	word (A) ← (io)	—	*	—	—	—	*	*	—	—	—
MOVW A, @A	2	3	0	(c)	word (A) ← ((A))	—	—	—	—	—	*	*	—	—	—
MOVW A, #imm16	3	2	0	0	word (A) ← imm16	—	*	—	—	—	*	*	—	—	—
MOVW A, @RWi+disp8	2	5	1	(c)	word (A) ← ((RWi) +disp8)	—	*	—	—	—	*	*	—	—	—
MOVW A, @RLi+disp8	3	10	2	(c)	word (A) ← ((RLi) +disp8)	—	*	—	—	—	*	*	—	—	—
MOVW dir, A	2	3	0	(c)	word (dir) ← (A)	—	—	—	—	—	*	*	—	—	—
MOVW addr16, A	3	4	0	(c)	word (addr16) ← (A)	—	—	—	—	—	*	*	—	—	—
MOVW SP, A	1	1	0	0	word (SP) ← (A)	—	—	—	—	—	*	*	—	—	—
MOVW RWi, A	1	2	1	0	word (RWi) ← (A)	—	—	—	—	—	*	*	—	—	—
MOVW ear, A	2	2	1	0	word (ear) ← (A)	—	—	—	—	—	*	*	—	—	—
MOVW eam, A	2+	3+ (a)	0	(c)	word (eam) ← (A)	—	—	—	—	—	*	*	—	—	—
MOVW io, A	2	3	0	(c)	word (io) ← (A)	—	—	—	—	—	*	*	—	—	—
MOVW @RWi+disp8, A	2	5	1	(c)	word ((RWi) +disp8) ← (A)	—	—	—	—	—	*	*	—	—	—
MOVW @RLi+disp8, A	3	10	2	(c)	word ((RLi) +disp8) ← (A)	—	—	—	—	—	*	*	—	—	—
MOVW RWi, ear	2	3	2	(0)	word (RWi) ← (ear)	—	—	—	—	—	*	*	—	—	—
MOVW RWi, eam	2+	4+ (a)	1	(c)	word (RWi) ← (eam)	—	—	—	—	—	*	*	—	—	—
MOVW ear, RWi	2	4	2	0	word (ear) ← (RWi)	—	—	—	—	—	*	*	—	—	—
MOVW eam, RWi	2+	5+ (a)	1	(c)	word (eam) ← (RWi)	—	—	—	—	—	*	*	—	—	—
MOVW RWi, #imm16	3	2	1	0	word (RWi) ← imm16	—	—	—	—	—	*	*	—	—	—
MOVW io, #imm16	4	5	0	(c)	word (io) ← imm16	—	—	—	—	—	—	—	—	—	—
MOVW ear, #imm16	4	2	1	0	word (ear) ← imm16	—	—	—	—	—	*	*	—	—	—
MOVW eam, #imm16	4+	4+ (a)	0	(c)	word (eam) ← imm16	—	—	—	—	—	—	—	—	—	—
MOVW @AL, AH	2	3	0	(c)	word ((A)) ← (AH)	—	—	—	—	—	*	*	—	—	—
XCHW A, ear	2	4	2	0	word (A) ↔ (ear)	—	—	—	—	—	—	—	—	—	—
XCHW A, eam	2+	5+ (a)	0	2× (c)	word (A) ↔ (eam)	—	—	—	—	—	—	—	—	—	—
XCHW RWi, ear	2	7	4	0	word (RWi) ↔ (ear)	—	—	—	—	—	—	—	—	—	—
XCHW RWi, eam	2+	9+ (a)	2	2× (c)	word (RWi) ↔ (eam)	—	—	—	—	—	—	—	—	—	—
MOVL A, ear	2	4	2	0	long (A) ← (ear)	—	—	—	—	—	*	*	—	—	—
MOVL A, eam	2+	5+ (a)	0	(d)	long (A) ← (eam)	—	—	—	—	—	*	*	—	—	—
MOVL A, #imm32	5	3	0	0	long (A) ← imm32	—	—	—	—	—	*	*	—	—	—
MOVL ear, A	2	4	2	0	long (ear) ← (A)	—	—	—	—	—	*	*	—	—	—
MOVL eam, A	2+	5+ (a)	0	(d)	long (eam) ← (A)	—	—	—	—	—	*	*	—	—	—

Note: For an explanation of “(a)” to “(d)”, refer to Table 4, “Number of Execution Cycles for Each Type of Addressing,” and Table 5, “Correction Values for Number of Cycles Used to Calculate Number of Actual Cycles.”

MB90650A Series

Table 9 Addition and Subtraction Instructions (Byte/Word/Long Word) [42 Instructions]

Mnemonic	#	~	RG	B	Operation	LH	AH	I	S	T	N	Z	V	C	RMW
ADD A, #imm8	2	2	0	0	byte (A) ← (A) +imm8	Z	—	—	—	—	*	*	*	*	—
ADD A, dir	2	5	0	(b)	byte (A) ← (A) +(dir)	Z	—	—	—	—	*	*	*	*	—
ADD A, ear	2	3	1	0	byte (A) ← (A) +(ear)	Z	—	—	—	—	*	*	*	*	—
ADD A, eam	2+	4+ (a)	0	(b)	byte (A) ← (A) +(eam)	Z	—	—	—	—	*	*	*	*	—
ADD ear, A	2	3	2	0	byte (ear) ← (ear) + (A)	—	—	—	—	—	*	*	*	*	—
ADD eam, A	2+	5+ (a)	0	2× (b)	byte (eam) ← (eam) + (A)	Z	—	—	—	—	*	*	*	*	*
ADDC A	1	2	0	0	byte (A) ← (AH) + (AL) + (C)	Z	—	—	—	—	*	*	*	*	—
ADDC A, ear	2	3	1	0	byte (A) ← (A) + (ear) + (C)	Z	—	—	—	—	*	*	*	*	—
ADDC A, eam	2+	4+ (a)	0	(b)	byte (A) ← (A) + (eam) + (C)	Z	—	—	—	—	*	*	*	*	—
ADDDC A	1	3	0	0	byte (A) ← (AH) + (AL) + (C) (decimal)	Z	—	—	—	—	*	*	*	*	—
SUB A, #imm8	2	2	0	0	byte (A) ← (A) -imm8	Z	—	—	—	—	*	*	*	*	—
SUB A, dir	2	5	0	(b)	byte (A) ← (A) - (dir)	Z	—	—	—	—	*	*	*	*	—
SUB A, ear	2	3	1	0	byte (A) ← (A) - (ear)	Z	—	—	—	—	*	*	*	*	—
SUB A, eam	2+	4+ (a)	0	(b)	byte (A) ← (A) - (eam)	Z	—	—	—	—	*	*	*	*	—
SUB ear, A	2	3	2	0	byte (ear) ← (ear) - (A)	—	—	—	—	—	*	*	*	*	—
SUB eam, A	2+	5+ (a)	0	2× (b)	byte (eam) ← (eam) - (A)	—	—	—	—	—	*	*	*	*	*
SUBC A	1	2	0	0	byte (A) ← (AH) - (AL) - (C)	Z	—	—	—	—	*	*	*	*	—
SUBC A, ear	2	3	1	0	byte (A) ← (A) - (ear) - (C)	Z	—	—	—	—	*	*	*	*	—
SUBC A, eam	2+	4+ (a)	0	(b)	byte (A) ← (A) - (eam) - (C)	Z	—	—	—	—	*	*	*	*	—
SUBDC A	1	3	0	0	byte (A) ← (AH) - (AL) - (C) (decimal)	Z	—	—	—	—	*	*	*	*	—
ADDW A	1	2	0	0	word (A) ← (AH) + (AL)	—	—	—	—	—	*	*	*	*	—
ADDW A, ear	2	3	1	0	word (A) ← (A) +(ear)	—	—	—	—	—	*	*	*	*	—
ADDW A, eam	2+	4+ (a)	0	(c)	word (A) ← (A) +(eam)	—	—	—	—	—	*	*	*	*	—
ADDW A, #imm16	3	2	0	0	word (A) ← (A) +imm16	—	—	—	—	—	*	*	*	*	—
ADDW ear, A	2	3	2	0	word (ear) ← (ear) + (A)	—	—	—	—	—	*	*	*	*	—
ADDW eam, A	2+	5+ (a)	0	2× (c)	word (eam) ← (eam) + (A)	—	—	—	—	—	*	*	*	*	*
ADDCW A, ear	2	3	1	0	word (A) ← (A) + (ear) + (C)	—	—	—	—	—	*	*	*	*	—
ADDCW A, eam	2+	4+ (a)	0	(c)	word (A) ← (A) + (eam) + (C)	—	—	—	—	—	*	*	*	*	—
SUBW A	1	2	0	0	word (A) ← (AH) - (AL)	—	—	—	—	—	*	*	*	*	—
SUBW A, ear	2	3	1	0	word (A) ← (A) - (ear)	—	—	—	—	—	*	*	*	*	—
SUBW A, eam	2+	4+ (a)	0	(c)	word (A) ← (A) - (eam)	—	—	—	—	—	*	*	*	*	—
SUBW A, #imm16	3	2	0	0	word (A) ← (A) -imm16	—	—	—	—	—	*	*	*	*	—
SUBW ear, A	2	3	2	0	word (ear) ← (ear) - (A)	—	—	—	—	—	*	*	*	*	—
SUBW eam, A	2+	5+ (a)	0	2× (c)	word (eam) ← (eam) - (A)	—	—	—	—	—	*	*	*	*	*
SUBCW A, ear	2	3	1	0	word (A) ← (A) - (ear) - (C)	—	—	—	—	—	*	*	*	*	—
SUBCW A, eam	2+	4+ (a)	0	(c)	word (A) ← (A) - (eam) - (C)	—	—	—	—	—	*	*	*	*	—
ADDL A, ear	2	6	2	0	long (A) ← (A) + (ear)	—	—	—	—	—	*	*	*	*	—
ADDL A, eam	2+	7+ (a)	0	(d)	long (A) ← (A) + (eam)	—	—	—	—	—	*	*	*	*	—
ADDL A, #imm32	5	4	0	0	long (A) ← (A) +imm32	—	—	—	—	—	*	*	*	*	—
SUBL A, ear	2	6	2	0	long (A) ← (A) - (ear)	—	—	—	—	—	*	*	*	*	—
SUBL A, eam	2+	7+ (a)	0	(d)	long (A) ← (A) - (eam)	—	—	—	—	—	*	*	*	*	—
SUBL A, #imm32	5	4	0	0	long (A) ← (A) -imm32	—	—	—	—	—	*	*	*	*	—

Note: For an explanation of “(a)” to “(d)”, refer to Table 4, “Number of Execution Cycles for Each Type of Addressing,” and Table 5, “Correction Values for Number of Cycles Used to Calculate Number of Actual Cycles.”

MB90650A Series

Table 10 Increment and Decrement Instructions (Byte/Word/Long Word) [12 Instructions]

Mnemonic		#	~	RG	B	Operation	LH	AH	I	S	T	N	Z	V	C	RMW
INC	ear	2	2	2	0	byte (ear) ← (ear) +1	–	–	–	–	–	*	*	*	–	–
INC	eam	2+	5+ (a)	0	2× (b)	byte (eam) ← (eam) +1	–	–	–	–	–	*	*	*	–	*
DEC	ear	2	3	2	0	byte (ear) ← (ear) –1	–	–	–	–	–	*	*	*	–	–
DEC	eam	2+	5+ (a)	0	2× (b)	byte (eam) ← (eam) –1	–	–	–	–	–	*	*	*	–	*
INCW	ear	2	3	2	0	word (ear) ← (ear) +1	–	–	–	–	–	*	*	*	–	–
INCW	eam	2+	5+ (a)	0	2× (c)	word (eam) ← (eam) +1	–	–	–	–	–	*	*	*	–	*
DECW	ear	2	3	2	0	word (ear) ← (ear) –1	–	–	–	–	–	*	*	*	–	–
DECW	eam	2+	5+ (a)	0	2× (c)	word (eam) ← (eam) –1	–	–	–	–	–	*	*	*	–	*
INCL	ear	2	7	4	0	long (ear) ← (ear) +1	–	–	–	–	–	*	*	*	–	–
INCL	eam	2+	9+ (a)	0	2× (d)	long (eam) ← (eam) +1	–	–	–	–	–	*	*	*	–	*
DECL	ear	2	7	4	0	long (ear) ← (ear) –1	–	–	–	–	–	*	*	*	–	–
DECL	eam	2+	9+ (a)	0	2× (d)	long (eam) ← (eam) –1	–	–	–	–	–	*	*	*	–	*

Note: For an explanation of “(a)” to “(d)”, refer to Table 4, “Number of Execution Cycles for Each Type of Addressing,” and Table 5, “Correction Values for Number of Cycles Used to Calculate Number of Actual Cycles.”

Table 11 Compare Instructions (Byte/Word/Long Word) [11 Instructions]

Mnemonic		#	~	RG	B	Operation	LH	AH	I	S	T	N	Z	V	C	RMW
CMP	A	1	1	0	0	byte (AH) – (AL)	–	–	–	–	–	*	*	*	*	–
CMP	A, ear	2	2	1	0	byte (A) ← (ear)	–	–	–	–	–	*	*	*	*	–
CMP	A, eam	2+	3+ (a)	0	(b)	byte (A) ← (eam)	–	–	–	–	–	*	*	*	*	–
CMP	A, #imm8	2	2	0	0	byte (A) ← imm8	–	–	–	–	–	*	*	*	*	–
CMPW	A	1	1	0	0	word (AH) – (AL)	–	–	–	–	–	*	*	*	*	–
CMPW	A, ear	2	2	1	0	word (A) ← (ear)	–	–	–	–	–	*	*	*	*	–
CMPW	A, eam	2+	3+ (a)	0	(c)	word (A) ← (eam)	–	–	–	–	–	*	*	*	*	–
CMPW	A, #imm16	3	2	0	0	word (A) ← imm16	–	–	–	–	–	*	*	*	*	–
CMPL	A, ear	2	6	2	0	word (A) ← (ear)	–	–	–	–	–	*	*	*	*	–
CMPL	A, eam	2+	7+ (a)	0	(d)	word (A) ← (eam)	–	–	–	–	–	*	*	*	*	–
CMPL	A, #imm32	5	3	0	0	word (A) ← imm32	–	–	–	–	–	*	*	*	*	–

Note: For an explanation of “(a)” to “(d)”, refer to Table 4, “Number of Execution Cycles for Each Type of Addressing,” and Table 5, “Correction Values for Number of Cycles Used to Calculate Number of Actual Cycles.”

MB90650A Series

Table 12 Multiplication and Division Instructions (Byte/Word/Long Word) [11 Instructions]

Mnemonic	#	~	RG	B	Operation	LH	AH	I	S	T	N	Z	V	C	RMW
DIVU A	1	*1	0	0	word (AH) /byte (AL) Quotient → byte (AL) Remainder → byte (AH)	—	—	—	—	—	—	—	*	*	—
DIVU A, ear	2	*2	1	0	word (A)/byte (ear) Quotient → byte (A) Remainder → byte (ear)	—	—	—	—	—	—	—	*	*	—
DIVU A, eam	2+	*3	0	*6	word (A)/byte (eam) Quotient → byte (A) Remainder → byte (eam)	—	—	—	—	—	—	—	*	*	—
DIVUW A, ear	2	*4	1	0	long (A)/word (ear) Quotient → word (A) Remainder → word (ear)	—	—	—	—	—	—	—	*	*	—
DIVUW A, eam	2+	*5	0	*7	long (A)/word (eam) Quotient → word (A) Remainder → word (ear)	—	—	—	—	—	—	—	*	*	—
MULU A	1	*8	0	0	byte (AH) *byte (AL) → word (A)	—	—	—	—	—	—	—	—	—	—
MULU A, ear	2	*9	1	0	byte (A) *byte (ear) → word (A)	—	—	—	—	—	—	—	—	—	—
MULU A, eam	2+	*10	0	(b)	byte (A) *byte (eam) → word (A)	—	—	—	—	—	—	—	—	—	—
MULUW A	1	*11	0	0	word (AH) *word (AL) → long (A)	—	—	—	—	—	—	—	—	—	—
MULUW A, ear	2	*12	1	0	word (A) *word (ear) → long (A)	—	—	—	—	—	—	—	—	—	—
MULUW A, eam	2+	*13	0	(c)	word (A) *word (eam) → long (A)	—	—	—	—	—	—	—	—	—	—

*1: 3 when the result is zero, 7 when an overflow occurs, and 15 normally.

*2: 4 when the result is zero, 8 when an overflow occurs, and 16 normally.

*3: 6 + (a) when the result is zero, 9 + (a) when an overflow occurs, and 19 + (a) normally.

*4: 4 when the result is zero, 7 when an overflow occurs, and 22 normally.

*5: 6 + (a) when the result is zero, 8 + (a) when an overflow occurs, and 26 + (a) normally.

*6: (b) when the result is zero or when an overflow occurs, and $2 \times (b)$ normally.

*7: (c) when the result is zero or when an overflow occurs, and $2 \times (c)$ normally.

*8: 3 when byte (AH) is zero, and 7 when byte (AH) is not zero.

*9: 4 when byte (ear) is zero, and 8 when byte (ear) is not zero.

*10: 5 + (a) when byte (eam) is zero, and 9 + (a) when byte (eam) is not 0.

*11: 3 when word (AH) is zero, and 11 when word (AH) is not zero.

*12: 4 when word (ear) is zero, and 12 when word (ear) is not zero.

*13: 5 + (a) when word (eam) is zero, and 13 + (a) when word (eam) is not zero.

Note: For an explanation of “(a)” to “(d)”, refer to Table 4, “Number of Execution Cycles for Each Type of Addressing,” and Table 5, “Correction Values for Number of Cycles Used to Calculate Number of Actual Cycles.”

Table 13 Logical 1 Instructions (Byte/Word) [39 Instructions]

Mnemonic	#	~	RG	B	Operation	LH	AH	I	S	T	N	Z	V	C	RMW
AND A, #imm8	2	2	0	0	byte (A) ← (A) and imm8	-	-	-	-	-	*	*	R	-	-
AND A, ear	2	3	1	0	byte (A) ← (A) and (ear)	-	-	-	-	-	*	*	R	-	-
AND A, eam	2+	4+ (a)	0	(b)	byte (A) ← (A) and (eam)	-	-	-	-	-	*	*	R	-	-
AND ear, A	2	3	2	0	byte (ear) ← (ear) and (A)	-	-	-	-	-	*	*	R	-	-
AND eam, A	2+	5+ (a)	0	2× (b)	byte (eam) ← (eam) and (A)	-	-	-	-	-	*	*	R	-	*
OR A, #imm8	2	2	0	0	byte (A) ← (A) or imm8	-	-	-	-	-	*	*	R	-	-
OR A, ear	2	3	1	0	byte (A) ← (A) or (ear)	-	-	-	-	-	*	*	R	-	-
OR A, eam	2+	4+ (a)	0	(b)	byte (A) ← (A) or (eam)	-	-	-	-	-	*	*	R	-	-
OR ear, A	2	3	2	0	byte (ear) ← (ear) or (A)	-	-	-	-	-	*	*	R	-	-
OR eam, A	2+	5+ (a)	0	2× (b)	byte (eam) ← (eam) or (A)	-	-	-	-	-	*	*	R	-	*
XOR A, #imm8	2	2	0	0	byte (A) ← (A) xor imm8	-	-	-	-	-	*	*	R	-	-
XOR A, ear	2	3	1	0	byte (A) ← (A) xor (ear)	-	-	-	-	-	*	*	R	-	-
XOR A, eam	2+	4+ (a)	0	(b)	byte (A) ← (A) xor (eam)	-	-	-	-	-	*	*	R	-	-
XOR ear, A	2	3	2	0	byte (ear) ← (ear) xor (A)	-	-	-	-	-	*	*	R	-	-
XOR eam, A	2+	5+ (a)	0	2× (b)	byte (eam) ← (eam) xor (A)	-	-	-	-	-	*	*	R	-	*
NOT A	1	2	0	0	byte (A) ← not (A)	-	-	-	-	-	*	*	R	-	-
NOT ear	2	3	2	0	byte (ear) ← not (ear)	-	-	-	-	-	*	*	R	-	-
NOT eam	2+	5+ (a)	0	2× (b)	byte (eam) ← not (eam)	-	-	-	-	-	*	*	R	-	*
ANDW A	1	2	0	0	word (A) ← (AH) and (A)	-	-	-	-	-	*	*	R	-	-
ANDW A, #imm16	3	2	0	0	word (A) ← (A) and imm16	-	-	-	-	-	*	*	R	-	-
ANDW A, ear	2	3	1	0	word (A) ← (A) and (ear)	-	-	-	-	-	*	*	R	-	-
ANDW A, eam	2+	4+ (a)	0	(c)	word (A) ← (A) and (eam)	-	-	-	-	-	*	*	R	-	-
ANDW ear, A	2	3	2	0	word (ear) ← (ear) and (A)	-	-	-	-	-	*	*	R	-	-
ANDW eam, A	2+	5+ (a)	0	2× (c)	word (eam) ← (eam) and (A)	-	-	-	-	-	*	*	R	-	*
ORW A	1	2	0	0	word (A) ← (AH) or (A)	-	-	-	-	-	*	*	R	-	-
ORW A, #imm16	3	2	0	0	word (A) ← (A) or imm16	-	-	-	-	-	*	*	R	-	-
ORW A, ear	2	3	1	0	word (A) ← (A) or (ear)	-	-	-	-	-	*	*	R	-	-
ORW A, eam	2+	4+ (a)	0	(c)	word (A) ← (A) or (eam)	-	-	-	-	-	*	*	R	-	-
ORW ear, A	2	3	2	0	word (ear) ← (ear) or (A)	-	-	-	-	-	*	*	R	-	-
ORW eam, A	2+	5+ (a)	0	2× (c)	word (eam) ← (eam) or (A)	-	-	-	-	-	*	*	R	-	*
XORW A	1	2	0	0	word (A) ← (AH) xor (A)	-	-	-	-	-	*	*	R	-	-
XORW A, #imm16	3	2	0	0	word (A) ← (A) xor imm16	-	-	-	-	-	*	*	R	-	-
XORW A, ear	2	3	1	0	word (A) ← (A) xor (ear)	-	-	-	-	-	*	*	R	-	-
XORW A, eam	2+	4+ (a)	0	(c)	word (A) ← (A) xor (eam)	-	-	-	-	-	*	*	R	-	-
XORW ear, A	2	3	2	0	word (ear) ← (ear) xor (A)	-	-	-	-	-	*	*	R	-	-
XORW eam, A	2+	5+ (a)	0	2× (c)	word (eam) ← (eam) xor (A)	-	-	-	-	-	*	*	R	-	*
NOTW A	1	2	0	0	word (A) ← not (A)	-	-	-	-	-	*	*	R	-	-
NOTW ear	2	3	2	0	word (ear) ← not (ear)	-	-	-	-	-	*	*	R	-	-
NOTW eam	2+	5+ (a)	0	2× (c)	word (eam) ← not (eam)	-	-	-	-	-	*	*	R	-	*

Note: For an explanation of “(a)” to “(d)”, refer to Table 4, “Number of Execution Cycles for Each Type of Addressing,” and Table 5, “Correction Values for Number of Cycles Used to Calculate Number of Actual Cycles.”

MB90650A Series

Table 14 Logical 2 Instructions (Long Word) [6 Instructions]

Mnemonic	#	~	RG	B	Operation	LH	AH	I	S	T	N	Z	V	C	RMW
ANDL A, ear	2	6	2	0	long (A) ← (A) and (ear)	–	–	–	–	–	*	*	R	–	–
ANDL A, eam	2+	7+ (a)	0	(d)	long (A) ← (A) and (eam)	–	–	–	–	–	*	*	R	–	–
ORL A, ear	2	6	2	0	long (A) ← (A) or (ear)	–	–	–	–	–	*	*	R	–	–
ORL A, eam	2+	7+ (a)	0	(d)	long (A) ← (A) or (eam)	–	–	–	–	–	*	*	R	–	–
XORL A, ea	2	6	2	0	long (A) ← (A) xor (ear)	–	–	–	–	–	*	*	R	–	–
XORL A, eam	2+	7+ (a)	0	(d)	long (A) ← (A) xor (eam)	–	–	–	–	–	*	*	R	–	–

Table 15 Sign Inversion Instructions (Byte/Word) [6 Instructions]

Mnemonic	#	~	RG	B	Operation	LH	AH	I	S	T	N	Z	V	C	RMW
NEG A	1	2	0	0	byte (A) ← 0 – (A)	X	–	–	–	–	*	*	*	*	–
NEG ear	2	3	2	0	byte (ear) ← 0 – (ear)	–	–	–	–	–	*	*	*	*	–
NEG eam	2+	5+ (a)	0	2× (b)	byte (eam) ← 0 – (eam)	–	–	–	–	–	*	*	*	*	*
NEGW A	1	2	0	0	word (A) ← 0 – (A)	–	–	–	–	–	*	*	*	*	–
NEGW ear	2	3	2	0	word (ear) ← 0 – (ear)	–	–	–	–	–	*	*	*	*	–
NEGW eam	2+	5+ (a)	0	2× (c)	word (eam) ← 0 – (eam)	–	–	–	–	–	*	*	*	*	*

Table 16 Normalize Instruction (Long Word) [1 Instruction]

Mnemonic	#	~	RG	B	Operation	LH	AH	I	S	T	N	Z	V	C	RMW
NRML A, R0	2	*1	1	0	long (A) ← Shift until first digit is “1” byte (R0) ← Current shift count	–	–	–	–	–	–	*	–	–	–

*1: 4 when the contents of the accumulator are all zeroes, 6 + (R0) in all other cases (shift count).

Note: For an explanation of “(a)” to “(d)”, refer to Table 4, “Number of Execution Cycles for Each Type of Addressing,” and Table 5, “Correction Values for Number of Cycles Used to Calculate Number of Actual Cycles.”

Table 17 Shift Instructions (Byte/Word/Long Word) [18 Instructions]

Mnemonic	#	~	RG	B	Operation	LH	AH	I	S	T	N	Z	V	C	RMW
RORC A	2	2	0	0	byte (A) ← Right rotation with carry	—	—	—	—	—	*	*	—	*	—
ROLC A	2	2	0	0	byte (A) ← Left rotation with carry	—	—	—	—	—	*	*	—	*	—
RORC ear	2	3	2	0	byte (ear) ← Right rotation with carry	—	—	—	—	—	*	*	—	*	—
RORC eam	2+	5+ (a)	0	2× (b)	byte (eam) ← Right rotation with carry	—	—	—	—	—	*	*	—	*	*
ROLC ear	2	3	2	0	byte (ear) ← Left rotation with carry	—	—	—	—	—	*	*	—	*	—
ROLC eam	2+	5+ (a)	0	2× (b)	byte (eam) ← Left rotation with carry	—	—	—	—	—	*	*	—	*	*
ASR A, R0	2	*1	1	0	byte (A) ← Arithmetic right barrel shift (A, R0)	—	—	—	—	*	*	*	—	*	—
LSR A, R0	2	*1	1	0	byte (A) ← Logical right barrel shift (A, R0)	—	—	—	—	*	*	*	—	*	—
LSL A, R0	2	*1	1	0	byte (A) ← Logical left barrel shift (A, R0)	—	—	—	—	—	*	*	—	*	—
ASRWA	1	2	0	0	word (A) ← Arithmetic right shift (A, 1 bit)	—	—	—	—	*	*	*	—	*	—
LSRW A/SHRW A	1	2	0	0	word (A) ← Logical right shift (A, 1 bit)	—	—	—	—	*	R	*	—	*	—
LSLW A/SHLW A	1	2	0	0	word (A) ← Logical left shift (A, 1 bit)	—	—	—	—	—	*	*	—	*	—
ASRWA, R0	2	*1	1	0	word (A) ← Arithmetic right barrel shift (A, R0)	—	—	—	—	*	*	*	—	*	—
LSRW A, R0	2	*1	1	0	word (A) ← Logical right barrel shift (A, R0)	—	—	—	—	*	*	*	—	*	—
LSLW A, R0	2	*1	1	0	word (A) ← Logical left barrel shift (A, R0)	—	—	—	—	—	*	*	—	*	—
ASRL A, R0	2	*2	1	0	long (A) ← Arithmetic right shift (A, R0)	—	—	—	—	*	*	*	—	*	—
LSRL A, R0	2	*2	1	0	long (A) ← Logical right barrel shift (A, R0)	—	—	—	—	*	*	*	—	*	—
LSLL A, R0	2	*2	1	0	long (A) ← Logical left barrel shift (A, R0)	—	—	—	—	—	*	*	—	*	—

*1: 6 when R0 is 0, 5 + (R0) in all other cases.

*2: 6 when R0 is 0, 6 + (R0) in all other cases.

Note: For an explanation of “(a)” to “(d)”, refer to Table 4, “Number of Execution Cycles for Each Type of Addressing,” and Table 5, “Correction Values for Number of Cycles Used to Calculate Number of Actual Cycles.”

MB90650A Series

Table 18 Branch 1 Instructions [31 Instructions]

Mnemonic	#	~	RG	B	Operation	LH	AH	I	S	T	N	Z	V	C	RMW
BZ/BEQ rel	2	*1	0	0	Branch when (Z) = 1	-	-	-	-	-	-	-	-	-	-
BNZ/BNE rel	2	*1	0	0	Branch when (Z) = 0	-	-	-	-	-	-	-	-	-	-
BC/BLO rel	2	*1	0	0	Branch when (C) = 1	-	-	-	-	-	-	-	-	-	-
BNC/BHS rel	2	*1	0	0	Branch when (C) = 0	-	-	-	-	-	-	-	-	-	-
BN rel	2	*1	0	0	Branch when (N) = 1	-	-	-	-	-	-	-	-	-	-
BP rel	2	*1	0	0	Branch when (N) = 0	-	-	-	-	-	-	-	-	-	-
BV rel	2	*1	0	0	Branch when (V) = 1	-	-	-	-	-	-	-	-	-	-
BNV rel	2	*1	0	0	Branch when (V) = 0	-	-	-	-	-	-	-	-	-	-
BT rel	2	*1	0	0	Branch when (T) = 1	-	-	-	-	-	-	-	-	-	-
BNT rel	2	*1	0	0	Branch when (T) = 0	-	-	-	-	-	-	-	-	-	-
BLT rel	2	*1	0	0	Branch when (V) xor (N) = 1	-	-	-	-	-	-	-	-	-	-
BGE rel	2	*1	0	0	Branch when (V) xor (N) = 0	-	-	-	-	-	-	-	-	-	-
BLE rel	2	*1	0	0	Branch when ((V) xor (N)) or (Z) = 1	-	-	-	-	-	-	-	-	-	-
BGT rel	2	*1	0	0	Branch when ((V) xor (N)) or (Z) = 0	-	-	-	-	-	-	-	-	-	-
BLS rel	2	*1	0	0	Branch when (C) or (Z) = 1	-	-	-	-	-	-	-	-	-	-
BHI rel	2	*1	0	0	Branch when (C) or (Z) = 0	-	-	-	-	-	-	-	-	-	-
BRA rel	2	*1	0	0	Branch unconditionally	-	-	-	-	-	-	-	-	-	-
JMP @A	1	2	0	0	word (PC) ← (A)	-	-	-	-	-	-	-	-	-	-
JMP addr16	3	3	0	0	word (PC) ← addr16	-	-	-	-	-	-	-	-	-	-
JMP @ear	2	3	1	0	word (PC) ← (ear)	-	-	-	-	-	-	-	-	-	-
JMP @eam	2+	4+ (a)	0	(c)	word (PC) ← (eam)	-	-	-	-	-	-	-	-	-	-
JMPP @ear *3	2	5	2	0	word (PC) ← (ear), (PCB) ← (ear +2)	-	-	-	-	-	-	-	-	-	-
JMPP @eam *3	2+	6+ (a)	0	(d)	word (PC) ← (eam), (PCB) ← (eam +2)	-	-	-	-	-	-	-	-	-	-
JMPP addr24	4	4	0	0	word (PC) ← ad24 0 to 15, (PCB) ← ad24 16 to 23	-	-	-	-	-	-	-	-	-	-
CALL @ear *4	2	6	1	(c)	word (PC) ← (ear)	-	-	-	-	-	-	-	-	-	-
CALL @eam *4	2+	7+ (a)	0	2× (c)	word (PC) ← (eam)	-	-	-	-	-	-	-	-	-	-
CALL addr16 *5	3	6	0	(c)	word (PC) ← addr16	-	-	-	-	-	-	-	-	-	-
CALLV #vct4 *5	1	7	0	2× (c)	Vector call instruction	-	-	-	-	-	-	-	-	-	-
CALLP @ear *6	2	10	2	2× (c)	word (PC) ← (ear) 0 to 15, (PCB) ← (ear) 16 to 23	-	-	-	-	-	-	-	-	-	-
CALLP @eam *6	2+	11+ (a)	0	*2	word (PC) ← (eam) 0 to 15, (PCB) ← (eam) 16 to 23	-	-	-	-	-	-	-	-	-	-
CALLP addr24 *7	4	10	0	2× (c)	word (PC) ← addr0 to 15, (PCB) ← addr16 to 23	-	-	-	-	-	-	-	-	-	-

*1: 4 when branching, 3 when not branching.

*2: (b) + 3 × (c)

*3: Read (word) branch address.

*4: W: Save (word) to stack; R: read (word) branch address.

*5: Save (word) to stack.

*6: W: Save (long word) to W stack; R: read (long word) R branch address.

*7: Save (long word) to stack.

Note: For an explanation of "(a)" to "(d)", refer to Table 4, "Number of Execution Cycles for Each Type of Addressing," and Table 5, "Correction Values for Number of Cycles Used to Calculate Number of Actual Cycles."

Table 19 Branch 2 Instructions [19 Instructions]

Mnemonic	#	~	RG	B	Operation	LH	AH	I	S	T	N	Z	V	C	RMW
CBNE A, #imm8, rel	3	*1	0	0	Branch when byte (A) \neq imm8	—	—	—	—	—	*	*	*	*	—
CWBNE A, #imm16, rel	4	*1	0	0	Branch when word (A) \neq imm16	—	—	—	—	—	*	*	*	*	—
CBNE ear, #imm8, rel	4	*2	1	0	Branch when byte (ear) \neq imm8	—	—	—	—	—	*	*	*	*	—
CBNE eam, #imm8, rel*9	4+	*3	0	(b)	Branch when byte (eam) \neq imm8	—	—	—	—	—	*	*	*	*	—
CWBNE ear, #imm16, rel	5	*4	1	0	Branch when word (ear) \neq imm16	—	—	—	—	—	*	*	*	*	—
CWBNE eam, #imm16, rel*9	5+	*3	0	(c)	Branch when word (eam) \neq imm16	—	—	—	—	—	*	*	*	*	—
DBNZ ear, rel	3	*5	2	0	Branch when byte (ear) = (ear) – 1, and (ear) \neq 0	—	—	—	—	—	*	*	*	—	—
DBNZ eam, rel	3+	*6	2	2 \times (b)	Branch when byte (eam) = (eam) – 1, and (eam) \neq 0	—	—	—	—	—	*	*	*	—	*
DWBNZ ear, rel	3	*5	2	0	Branch when word (ear) = (ear) – 1, and (ear) \neq 0	—	—	—	—	—	*	*	*	—	—
DWBNZ eam, rel	3+	*6	2	2 \times (c)	Branch when word (eam) = (eam) – 1, and (eam) \neq 0	—	—	—	—	—	*	*	*	—	*
INT #vct8	2	20	0	8 \times (c)	Software interrupt	—	—	R	S	—	—	—	—	—	—
INT addr16	3	16	0	6 \times (c)	Software interrupt	—	—	R	S	—	—	—	—	—	—
INTP addr24	4	17	0	6 \times (c)	Software interrupt	—	—	R	S	—	—	—	—	—	—
INT9	1	20	0	8 \times (c)	Software interrupt	—	—	R	S	—	—	—	—	—	—
RETI	1	15	0	6 \times (c)	Return from interrupt	—	—	*	*	*	*	*	*	*	—
LINK #local8	2	6	0	(c)	At constant entry, save old frame pointer to stack, set new frame pointer, and allocate local pointer area	—	—	—	—	—	—	—	—	—	—
UNLINK	1	5	0	(c)	At constant entry, retrieve old frame pointer from stack.	—	—	—	—	—	—	—	—	—	—
RET *7	1	4	0	(c)	Return from subroutine	—	—	—	—	—	—	—	—	—	—
RETP *8	1	6	0	(d)	Return from subroutine	—	—	—	—	—	—	—	—	—	—

*1: 5 when branching, 4 when not branching

*2: 13 when branching, 12 when not branching

*3: 7 + (a) when branching, 6 + (a) when not branching

*4: 8 when branching, 7 when not branching

*5: 7 when branching, 6 when not branching

*6: 8 + (a) when branching, 7 + (a) when not branching

*7: Retrieve (word) from stack

*8: Retrieve (long word) from stack

*9: In the CBNE/CWBNE instruction, do not use the RWj+ addressing mode.

Note: For an explanation of “(a)” to “(d)”, refer to Table 4, “Number of Execution Cycles for Each Type of Addressing,” and Table 5, “Correction Values for Number of Cycles Used to Calculate Number of Actual Cycles.”

MB90650A Series

Table 20 Other Control Instructions (Byte/Word/Long Word) [36 Instructions]

Mnemonic	#	~	RG	B	Operation	LH	AH	I	S	T	N	Z	V	C	RMW
PUSHW A	1	4	0	(c)	word (SP) ← (SP) -2, ((SP)) ← (A)	-	-	-	-	-	-	-	-	-	-
PUSHW AH	1	4	0	(c)	word (SP) ← (SP) -2, ((SP)) ← (AH)	-	-	-	-	-	-	-	-	-	-
PUSHW PS	1	4	0	(c)	word (SP) ← (SP) -2, ((SP)) ← (PS)	-	-	-	-	-	-	-	-	-	-
PUSHW rlst	2	*3	*5	*4	(SP) ← (SP) -2n, ((SP)) ← (rlst)	-	-	-	-	-	-	-	-	-	-
POPW A	1	3	0	(c)	word (A) ← ((SP)), (SP) ← (SP) +2	-	*	-	-	-	-	-	-	-	-
POPW AH	1	3	0	(c)	word (AH) ← ((SP)), (SP) ← (SP) +2	-	-	-	-	-	-	-	-	-	-
POPW PS	1	4	0	(c)	word (PS) ← ((SP)), (SP) ← (SP) +2	-	-	*	*	*	*	*	*	*	-
POPW rlst	2	*2	*5	*4	(rlst) ← ((SP)), (SP) ← (SP) +2n	-	-	-	-	-	-	-	-	-	-
JCTX @A	1	14	0	6× (c)	Context switch instruction	-	-	*	*	*	*	*	*	*	-
AND CCR, #imm8	2	3	0	0	byte (CCR) ← (CCR) and imm8	-	-	*	*	*	*	*	*	*	-
OR CCR, #imm8	2	3	0	0	byte (CCR) ← (CCR) or imm8	-	-	*	*	*	*	*	*	*	-
MOV RP, #imm8	2	2	0	0	byte (RP) ← imm8	-	-	-	-	-	-	-	-	-	-
MOV ILM, #imm8	2	2	0	0	byte (ILM) ← imm8	-	-	-	-	-	-	-	-	-	-
MOVEA RWi, ear	2	3	1	0	word (RWi) ← ear	-	-	-	-	-	-	-	-	-	-
MOVEA RWi, eam	2+	2+ (a)	1	0	word (RWi) ← eam	-	-	-	-	-	-	-	-	-	-
MOVEA A, ear	2	1	0	0	word(A) ← ear	-	*	-	-	-	-	-	-	-	-
MOVEA A, eam	2+	1+ (a)	0	0	word (A) ← eam	-	*	-	-	-	-	-	-	-	-
ADDSP #imm8	2	3	0	0	word (SP) ← (SP) +ext (imm8)	-	-	-	-	-	-	-	-	-	-
ADDSP #imm16	3	3	0	0	word (SP) ← (SP) +imm16	-	-	-	-	-	-	-	-	-	-
MOV A, brgl	2	*1	0	0	byte (A) ← (brgl)	Z	*	-	-	-	*	*	-	-	-
MOV brg2, A	2	1	0	0	byte (brg2) ← (A)	-	-	-	-	-	*	*	-	-	-
NOP	1	1	0	0	No operation	-	-	-	-	-	-	-	-	-	-
ADB	1	1	0	0	Prefix code for accessing AD space	-	-	-	-	-	-	-	-	-	-
DTB	1	1	0	0	Prefix code for accessing DT space	-	-	-	-	-	-	-	-	-	-
PCB	1	1	0	0	Prefix code for accessing PC space	-	-	-	-	-	-	-	-	-	-
SPB	1	1	0	0	Prefix code for accessing SP space	-	-	-	-	-	-	-	-	-	-
NCC	1	1	0	0	Prefix code for no flag change	-	-	-	-	-	-	-	-	-	-
CMR	1	1	0	0	Prefix code for common register bank	-	-	-	-	-	-	-	-	-	-

*1: PCB, ADB, SSB, USB, and SPB : 1 state
DTB, DPR : 2 states

*2: $7 + 3 \times (\text{pop count}) + 2 \times (\text{last register number to be popped})$, 7 when rlst = 0 (no transfer register)

*3: $29 + (\text{push count}) - 3 \times (\text{last register number to be pushed})$, 8 when rlst = 0 (no transfer register)

*4: Pop count × (c), or push count × (c)

*5: Pop count or push count.

Note: For an explanation of "(a)" to "(d)", refer to Table 4, "Number of Execution Cycles for Each Type of Addressing," and Table 5, "Correction Values for Number of Cycles Used to Calculate Number of Actual Cycles."

Table 21 Bit Manipulation Instructions [21 Instructions]

Mnemonic	#	~	RG	B	Operation	LH	AH	I	S	T	N	Z	V	C	RMW
MOVB A, dir:bp	3	5	0	(b)	byte (A) ← (dir:bp) b	Z	*	—	—	—	*	*	—	—	—
MOVB A, addr16:bp	4	5	0	(b)	byte (A) ← (addr16:bp) b	Z	*	—	—	—	*	*	—	—	—
MOVB A, io:bp	3	4	0	(b)	byte (A) ← (io:bp) b	Z	*	—	—	—	*	*	—	—	—
MOVB dir:bp, A	3	7	0	2× (b)	bit (dir:bp) b ← (A)	—	—	—	—	—	*	*	—	—	*
MOVB addr16:bp, A	4	7	0	2× (b)	bit (addr16:bp) b ← (A)	—	—	—	—	—	*	*	—	—	*
MOVB io:bp, A	3	6	0	2× (b)	bit (io:bp) b ← (A)	—	—	—	—	—	*	*	—	—	*
SETB dir:bp	3	7	0	2× (b)	bit (dir:bp) b ← 1	—	—	—	—	—	—	—	—	—	*
SETB addr16:bp	4	7	0	2× (b)	bit (addr16:bp) b ← 1	—	—	—	—	—	—	—	—	—	*
SETB io:bp	3	7	0	2× (b)	bit (io:bp) b ← 1	—	—	—	—	—	—	—	—	—	*
CLRB dir:bp	3	7	0	2× (b)	bit (dir:bp) b ← 0	—	—	—	—	—	—	—	—	—	*
CLRB addr16:bp	4	7	0	2× (b)	bit (addr16:bp) b ← 0	—	—	—	—	—	—	—	—	—	*
CLRB io:bp	3	7	0	2× (b)	bit (io:bp) b ← 0	—	—	—	—	—	—	—	—	—	*
BBC dir:bp, rel	4	*1	0	(b)	Branch when (dir:bp) b = 0	—	—	—	—	—	—	*	—	—	—
BBC addr16:bp, rel	5	*1	0	(b)	Branch when (addr16:bp) b = 0	—	—	—	—	—	—	*	—	—	—
BBC io:bp, rel	4	*2	0	(b)	Branch when (io:bp) b = 0	—	—	—	—	—	—	*	—	—	—
BBS dir:bp, rel	4	*1	0	(b)	Branch when (dir:bp) b = 1	—	—	—	—	—	—	*	—	—	—
BBS addr16:bp, rel	5	*1	0	(b)	Branch when (addr16:bp) b = 1	—	—	—	—	—	—	*	—	—	—
BBS io:bp, rel	4	*2	0	(b)	Branch when (io:bp) b = 1	—	—	—	—	—	—	*	—	—	—
SBBS addr16:bp, rel	5	*3	0	2× (b)	Branch when (addr16:bp) b = 1, bit = 1	—	—	—	—	—	—	*	—	—	*
WBTS io:bp	3	*4	0	*5	Wait until (io:bp) b = 1	—	—	—	—	—	—	—	—	—	—
WBTC io:bp	3	*4	0	*5	Wait until (io:bp) b = 0	—	—	—	—	—	—	—	—	—	—

*1: 8 when branching, 7 when not branching

*2: 7 when branching, 6 when not branching

*3: 10 when condition is satisfied, 9 when not satisfied

*4: Undefined count

*5: Until condition is satisfied

Note: For an explanation of “(a)” to “(d)”, refer to Table 4, “Number of Execution Cycles for Each Type of Addressing,” and Table 5, “Correction Values for Number of Cycles Used to Calculate Number of Actual Cycles.”

MB90650A Series

Table 22 Accumulator Manipulation Instructions (Byte/Word) [6 Instructions]

Mnemonic	#	~	RG	B	Operation	LH	AH	I	S	T	N	Z	V	C	RMW
SWAP	1	3	0	0	byte (A) 0 to 7 \leftrightarrow (A) 8 to 15	-	-	-	-	-	-	-	-	-	-
SWAPW	1	2	0	0	word (AH) \leftrightarrow (AL)	-	*	-	-	-	-	-	-	-	-
EXT	1	1	0	0	byte sign extension	X	-	-	-	-	*	*	-	-	-
EXTW	1	2	0	0	word sign extension	-	X	-	-	-	*	*	-	-	-
ZEXT	1	1	0	0	byte zero extension	Z	-	-	-	-	R	*	-	-	-
ZEXTW	1	1	0	0	word zero extension	-	Z	-	-	-	R	*	-	-	-

Table 23 String Instructions [10 Instructions]

Mnemonic	#	~	RG	B	Operation	LH	AH	I	S	T	N	Z	V	C	RMW
MOVS/MOVS	2	*2	*5	*3	Byte transfer @AH+ \leftarrow @AL+, counter = RW0	-	-	-	-	-	-	-	-	-	-
MOVSD	2	*2	*5	*3	Byte transfer @AH- \leftarrow @AL-, counter = RW0	-	-	-	-	-	-	-	-	-	-
SCEQ/SCEQI	2	*1	*5	*4	Byte retrieval (@AH+) - AL, counter = RW0	-	-	-	-	-	*	*	*	*	-
SCEQD	2	*1	*5	*4	Byte retrieval (@AH-) - AL, counter = RW0	-	-	-	-	-	*	*	*	*	-
FISL/FISLI	2	6m +6	*5	*3	Byte filling @AH+ \leftarrow AL, counter = RW0	-	-	-	-	-	*	*	-	-	-
MOVSW/MOVSWI	2	*2	*8	*6	Word transfer @AH+ \leftarrow @AL+, counter = RW0	-	-	-	-	-	-	-	-	-	-
MOVSWD	2	*2	*8	*6	Word transfer @AH- \leftarrow @AL-, counter = RW0	-	-	-	-	-	-	-	-	-	-
SCWEQ/SCWEQI	2	*1	*8	*7	Word retrieval (@AH+) - AL, counter = RW0	-	-	-	-	-	*	*	*	*	-
SCWEQD	2	*1	*8	*7	Word retrieval (@AH-) - AL, counter = RW0	-	-	-	-	-	*	*	*	*	-
FILSW/FILSWI	2	6m +6	*8	*6	Word filling @AH+ \leftarrow AL, counter = RW0	-	-	-	-	-	*	*	-	-	-

m: RW0 value (counter value)

n: Loop count

*1: 5 when RW0 is 0, $4 + 7 \times (RW0)$ for count out, and $7 \times n + 5$ when match occurs

*2: 5 when RW0 is 0, $4 + 8 \times (RW0)$ in any other case

*3: $(b) \times (RW0) + (b) \times (RW0)$ when accessing different areas for the source and destination, calculate (b) separately for each.

*4: $(b) \times n$

*5: $2 \times (RW0)$

*6: $(c) \times (RW0) + (c) \times (RW0)$ when accessing different areas for the source and destination, calculate (c) separately for each.

*7: $(c) \times n$

*8: $2 \times (RW0)$

Note: For an explanation of "(a)" to "(d)", refer to Table 4, "Number of Execution Cycles for Each Type of Addressing," and Table 5, "Correction Values for Number of Cycles Used to Calculate Number of Actual Cycles."

MB90650A Series

■ ORDERING INFORMATION

Model	Package	Remarks
MB90652APFV MB90653APFV MB90P653APFV	100-pin Plastic LQFP (FPT-100P-M05)	
MB90652APF MB90653APF MB90P653APF	100-pin Plastic QFP (FPT-100P-M06)	

MB90650A Series

PACKAGE DIMENSIONS

100-pin Plastic LQFP
(FPT-100P-M05)

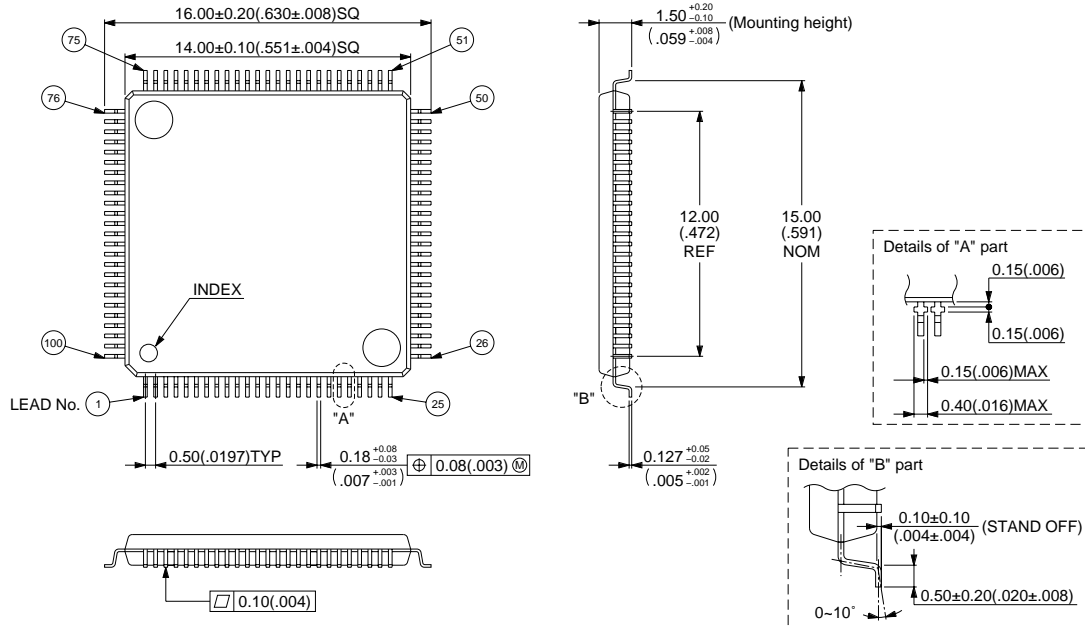

© 1995 FUJITSU LIMITED F100007S-2C-3

Dimensions in mm (inches)

100-pin Plastic QFP
(FPT-100P-M06)

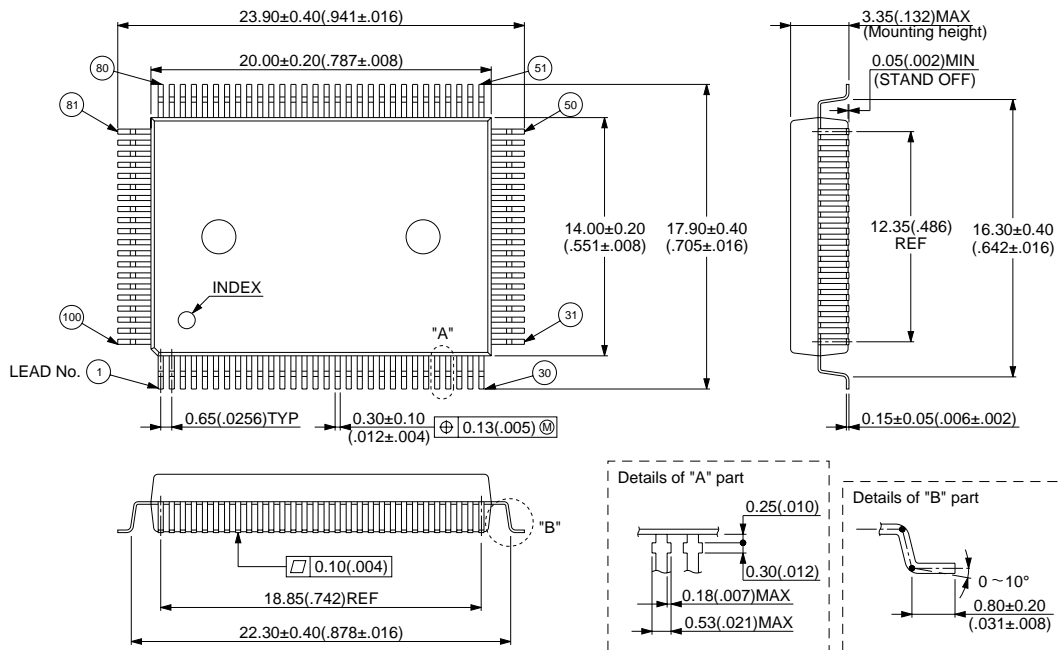

© 1994 FUJITSU LIMITED F100008-3C-2

Dimensions in mm (inches)

FUJITSU LIMITED

For further information please contact:

Japan

FUJITSU LIMITED
Corporate Global Business Support Division
Electronic Devices
KAWASAKI PLANT, 4-1-1, Kamikodanaka
Nakahara-ku, Kawasaki-shi
Kanagawa 211-8588, Japan
Tel: (044) 754-3763
Fax: (044) 754-3329

<http://www.fujitsu.co.jp/>

North and South America

FUJITSU MICROELECTRONICS, INC.
Semiconductor Division
3545 North First Street
San Jose, CA 95134-1804, USA
Tel: (408) 922-9000
Fax: (408) 922-9179

Customer Response Center
Mon. - Fri.: 7 am - 5 pm (PST)
Tel: (800) 866-8608
Fax: (408) 922-9179

<http://www.fujitsumicro.com/>

Europe

FUJITSU MIKROELEKTRONIK GmbH
Am Siebenstein 6-10
D-63303 Dreieich-Buchschlag
Germany
Tel: (06103) 690-0
Fax: (06103) 690-122

<http://www.fujitsu-edc.com/>

Asia Pacific

FUJITSU MICROELECTRONICS ASIA PTE LTD
#05-08, 151 Lorong Chuan
New Tech Park
Singapore 556741
Tel: (65) 281-0770
Fax: (65) 281-0220

<http://www.fmap.com.sg/>

F9803

© FUJITSU LIMITED Printed in Japan

All Rights Reserved.

The contents of this document are subject to change without notice. Customers are advised to consult with FUJITSU sales representatives before ordering.

The information and circuit diagrams in this document presented as examples of semiconductor device applications, and are not intended to be incorporated in devices for actual use. Also, FUJITSU is unable to assume responsibility for infringement of any patent rights or other rights of third parties arising from the use of this information or circuit diagrams.

FUJITSU semiconductor devices are intended for use in standard applications (computers, office automation and other office equipment, industrial, communications, and measurement equipment, personal or household devices, etc.).

CAUTION:

Customers considering the use of our products in special applications where failure or abnormal operation may directly affect human lives or cause physical injury or property damage, or where extremely high levels of reliability are demanded (such as aerospace systems, atomic energy controls, sea floor repeaters, vehicle operating controls, medical devices for life support, etc.) are requested to consult with FUJITSU sales representatives before such use. The company will not be responsible for damages arising from such use without prior approval.

Any semiconductor devices have inherently a certain rate of failure. You must protect against injury, damage or loss from such failures by incorporating safety design measures into your facility and equipment such as redundancy, fire protection, and prevention of over-current levels and other abnormal operating conditions.

If any products described in this document represent goods or technologies subject to certain restrictions on export under the Foreign Exchange and Foreign Trade Control Law of Japan, the prior authorization by Japanese government should be required for export of those products from Japan.